

YASKAWA AC Drive Option

CANopen Installation Manual

Model SI-S3

To properly use the product, read this manual thoroughly and retain for easy reference, inspection, and maintenance. Ensure the end user receives this manual.

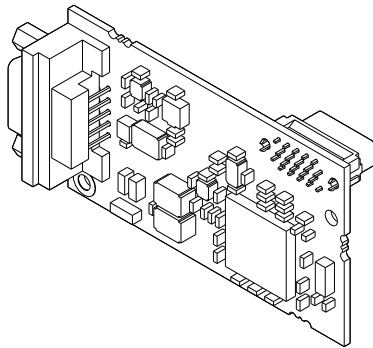

This Page Intentionally Blank

Table of Contents

1.	Preface and Safety	5
	Applicable Documentation	5
	Glossary	6
	Registered Trademarks	7
	Supplemental Safety Information	7
	Section Safety	7
2.	Overview	8
	Compatible Products	8
	Install the Option on a GA500 Drive	9
3.	Receiving	10
	Option Package Contents	11
	Installation Tools	12
4.	Option Components	13
	Option	13
	Communication Connector	13
	Option LED States	14
	Option LED Status Definitions.	14
5.	Installation Procedure	15
	Section Safety	15
	Procedures to Install and Wire Options on a Drive	16
	Procedure A	17
	Procedure B	22
	Procedure C	27
	Communication Cable Specifications	36
	Option Connection Diagram	36

Termination Resistor Connection	36
EDS Files	37
6. Related Drive Parameters	37
7. Bit Rate and Node ID Setup	41
Bit Rate Setup	41
Setting the Bit Rate Manually	41
Using Automatic Bit Rate Detection	42
Node ID Setup	42
8. Communication Objects Overview	43
Communication Profile Objects (DS 301)	43
Manufacturer Specific Profile Objects (DS 301)	44
Drives and Motion Profile Objects (DSP 402)	45
PDOs and Default PDO Setup	46
Receive PDOs (RxPDO)	46
Transmit PDOs (TxPDO)	47
9. Troubleshooting	48
Drive-Side Error Codes	48
Faults	48
Minor Faults and Alarms	51
10. European Standards	52
EMC Directive Compliance	52
Option Installation	52
11. United Kingdom Conformity Assessed Marking	55
12. Korean Radio Waves Act	56
13. Specifications	56
Specifications	56
14. Disposal	57
Disposal Instructions	57
WEEE Directive	57
Revision History	58

1 Preface and Safety

YASKAWA Electric supplies component parts for use in a wide variety of industrial applications. The selection and application of YASKAWA products remain the responsibility of the equipment designer or end user.

YASKAWA accepts no responsibility for the way its products are incorporated into the final system design. Under no circumstances should any YASKAWA product be incorporated into any product or design as the exclusive or sole safety control. Without exception, all controls should be designed to detect faults dynamically and fail safely under all circumstances. All products designed to incorporate a component part manufactured by YASKAWA must be supplied to the end user with appropriate warnings and instructions as to the safe use and operation of that part. Any warnings provided by YASKAWA must be promptly provided to the end user. YASKAWA offers an express warranty only as to the quality of its products in conforming to standards and specifications published in the manual. **NO OTHER WARRANTY, EXPRESS OR IMPLIED, IS OFFERED.** YASKAWA assumes no liability for any personal injury, property damage, losses, or claims arising from misapplication of its products.

◆ Applicable Documentation

These manuals are available for the option:

Document	Description
YASKAWA AC Drive Option CANopen Installation Manual (This book)	Read this manual first. The manual provides information about wiring, settings, functions, and troubleshooting. The manual is packaged together with the product.
YASKAWA AC Drive Option CANopen Technical Manual Manual No.: SIEP C730600 85	The technical manual contains detailed information about the option. Access the following sites to obtain the technical manual: U.S.: http://www.yaskawa.com Europe: http://www.yaskawa.eu.com Japan: http://www.e-mechatronics.com Other areas: Check the back cover of these manuals. For questions, contact Yaskawa or a Yaskawa representative.
YASKAWA AC Drive Manuals	Refer to the drive manual to connect with the option. Drive manuals contain basic installation and wiring information in addition to detailed parameter setting, fault diagnostic, and maintenance information. The manuals also include important information about parameter settings and tuning the drive. The Quick Start Guides are packaged with the drive. The most recent versions of these manuals are available for download on our documentation websites: U.S.: http://www.yaskawa.com Europe: http://www.yaskawa.eu.com Japan: http://www.e-mechatronics.com Other areas: Check the back cover of these manuals. For questions, contact Yaskawa or a Yaskawa representative.

◆ Glossary

Terms	Definition
Option	YASKAWA AC Drive Option CANopen
Keypad	<ul style="list-style-type: none"> • HOA Operator • LCD Operator • LED Operator • HOA Keypad • LCD Keypad • LED Keypad
Hex. (Example: 900 (Hex.))	Identifies a unit for hexadecimal number format.

◆ Registered Trademarks

- CANopen is a registered trademark of the CAN in Automation (CiA).
- QR Code is a registered trademark of DENSO WAVE INCORPORATED.
- Other company names and product names in this manual are trademarks or registered trademarks of the respective companies.

◆ Supplemental Safety Information

Read and understand this manual before installing, operating, or servicing this option. The option must be installed according to this manual and local codes.

The following conventions are used to indicate safety messages in this manual. Failure to heed these messages could result in serious or possibly even fatal injury or damage to the products or to related equipment and systems.

▲ DANGER *This signal word identifies a hazard that will cause serious injury or death if you do not prevent it.*

▲ WARNING *This signal word identifies a hazard that can cause death or serious injuries if you do not prevent it.*

▲ CAUTION *This signal word identifies a hazard that can cause minor or moderate injuries if you do not prevent it.*

NOTICE *This signal word identifies a property damage message that is not related to personal injury.*

■ Section Safety

General Precautions

- The diagrams in this section may include options and drives without covers or safety shields to illustrate details. Be sure to reinstall covers or shields before operating any devices. The option should be used according to the instructions described in this manual.
- The diagrams in this manual are provided as examples only and may not pertain to all products covered by this manual.
- The products and specifications described in this manual or the content and presentation of the manual may be changed without notice to improve the product and/or the manual.
- Contact Yaskawa or a Yaskawa representative and provide the manual number shown on the front cover to order new copies of the manual.

▲ DANGER *Do not ignore the safety messages in this manual. If you ignore the safety messages in this manual, it will cause serious injury or death. The manufacturer is not responsible for injuries or damage to equipment.*

▲ WARNING *Electrical Shock Hazard. Do not modify the drive or option circuitry. Failure to obey can cause serious injury or death, or cause damage to the drive or option and will void warranty. Yaskawa is not responsible for modifications of the product made by the user.*

NOTICE *Damage to Equipment. Do not use steam or other disinfectants to fumigate wood for packaging the drive. Use alternative methods, for example heat treatment, before you package the components. Gas from wood packaging fumigated with halogen disinfectants, for example fluorine, chlorine, bromine, iodine or DOP gas (phthalic acid ester), can cause damage to the drive.*

2 Overview

The CANopen Option (Model: SI-S3) is an option designed to connect the Yaskawa AC drive to a CANopen network.

Install the option/CANopen option on a drive to do these functions from a CANopen master device:

- Operate the drive
- Monitor the drive operation status
- Change drive parameter settings

The option supports these communication profiles:

- DS 301 Ver. 4.02
- DSP 402 Ver. 1.1 Velocity Mode

◆ Compatible Products

You can use the option with these products:

Table 2.1 Compatible Products

Product Series	Model(s)	Software Version ^{*/}
A1000	CIMR-Ax2Axxxx	≥ 1020
	CIMR-Ax4A0002 - 4A0675	
	CIMR-Ax4A0930, 4A1200	≥ 3015
U1000	CIMR-UxxAxxxx	≥ 1010
	CIMR-UxxExxxx	
	CIMR-UxxPxxxx	
	CIMR-UxxWxxxx	
U1000L	CIMR-UxxLxxxx	≥ 6210
	CIMR-UxxFxxxx	
	CIMR-UxxRxxxx	
	CIMR-UxxSxxxx	
Z1000U	CIMR-ZxxAxxxx	≥ 6110

Product Series	Model(s)	Software Version ^{*/}
	CIMR-ZxxExxxx	
	CIMR-ZxxPxxxx	
	CIMR-ZxxWxxxx	
GA500	CIPR-GA50xxxxx	≥ 1010
GA700	CIPR-GA70xxxxx	≥ 1010
GA800	CIPR-GA80xxxxx	≥ 9010
LA700	CIPR-LA70xxxxx	≥ 1010
FP605	CIPR-FP65xxxxx	≥ 1010

*1 Refer to "PRG" on the drive nameplate for the software version number.

Note:

- Refer to the option package labeling in the field designated "PRG (four digit number)" or the option labeling in the field to identify the option software version.
- For Yaskawa customers in the North or South America region:
If your product is not listed in [Table 2.1](#), refer to the web page below to confirm this manual is correct for your product. The web page provides a list of option manuals by product, and a direct link to download a PDF of the manual.

Scan QR code Or refer to:

<http://www.yaskawa.com/optionlookup>



◆ Install the Option on a GA500 Drive

An option card mounting kit is necessary to install the option on a GA500 drive. The option card mounting kit model is: JOHB-GA50. This kit is sold separately.

Refer to the option card mounting kit manual for more information about installation.

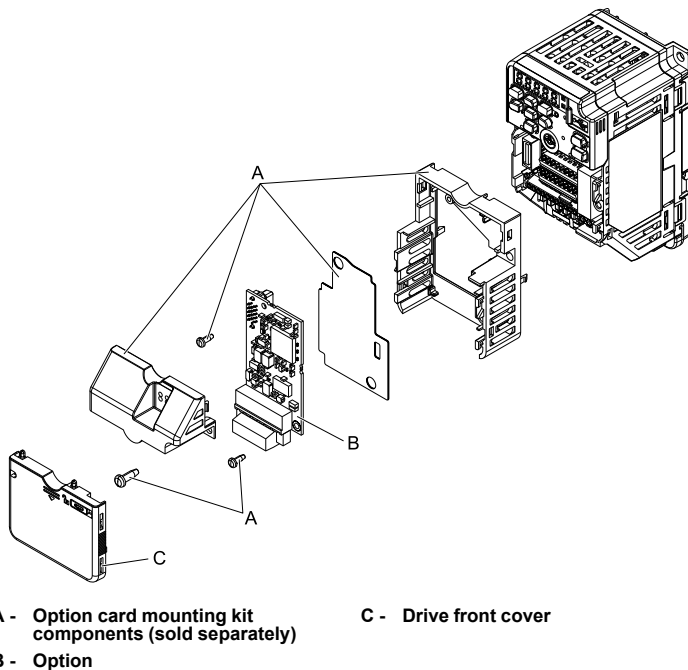

Figure 2.1 Option Card Mounting Kit (JOHB-GA50)

3 Receiving

After receiving the option package:

- Make sure that the option is not damaged and no parts are missing. The Yaskawa warranty does not include damage from shipping. Contact your sales outlet if the option or other parts appear damaged.





NOTICE

Damage to Equipment. Do not use damaged parts to connect the drive and the option. Failure to comply could damage the drive and option.

- Make sure that the model number on the option nameplate and the model number on the purchase order are the same. Refer to [Option on page 13](#) for more information.
- Contact the distributor where you purchased the option or contact Yaskawa or a Yaskawa representative about any problems with the option.

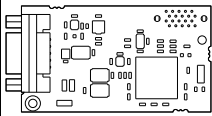
◆ Option Package Contents

Table 3.1 Contents of Package

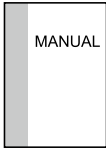
Option Contents		Quantity
Option		1
Ground Wire ^{*1}		1
Screws (M3)		3 ^{*2}
LED Labels	1000-Series 	1
	GA500, GA700, GA800, LA700 	1
Installation Manual		1

*1 GA700, GA800, and LA700 drives do not use the ground wire.

*2 Only two screws are necessary to install the option on GA700, GA800, LA700, and FP605 drives.

Note:

The LED label for FP605 drives is packaged with the FP605 drive.

UNP00694-1 LED indicator labels for optional network communication cards. If required, install on the front cover of drive over the LED indicators.		OPTION	
<u>RUN</u> ERR	<u>COMM</u> BF		SI-P3
<u>RUN</u> ERR	—		SI-S3
<u>MS</u> NS	—		SI-N3

◆ Installation Tools

You can use these tools to install the option to the drive:

- A Phillips screwdriver or slotted screwdriver (blade depth: 0.4 mm (0.02 in), width: 2.5 mm (0.1 in)) ^{*1}.
- A pair of diagonal cutting pliers.
- A small file or medium-grit sandpaper.

*1 Phillips screw sizes are different for different drive capacities. Prepare different screwdrivers for different screw sizes.

4 Option Components

◆ Option

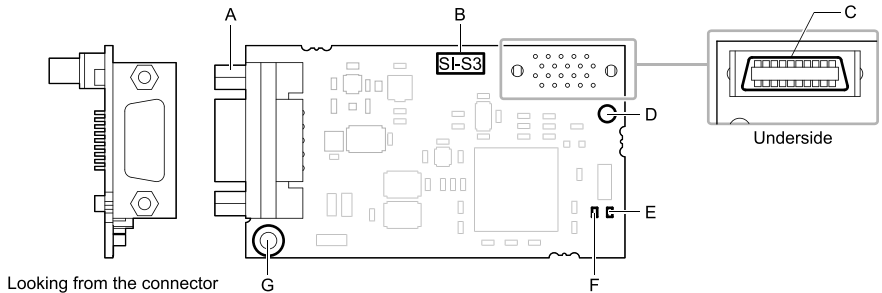

- A - Communication cable connector (9 pin D-sub)**
- B - Option model number**
- C - Connector (CN5)**
- D - Installation hole**
- E - LED (RUN) *1**
- F - LED (ERR) *1**
- G - Ground terminal (FE) and installation hole *2**

Figure 4.1 Option

*1 Refer to *Option LED States on page 14* for more information about the LEDs.

*2 Connect the included ground wire during installation. The ground wire is not necessary for installations on GA700, GA800, and LA700 drives.

◆ Communication Connector

The CANopen Option is connected to the network using a 9-pin D-sub connector. The pin assignment is explained in the table below.

Table 4.1 Communication connector (9-pin D-sub)

CANopen Connector	Pin	Signal	Description
	1	-	-
	2	CAN_L	CAN_H bus line (dominant high)
	3	CAN_GND	CAN Ground
	4	-	-
	5	CAN_SHLD	CAN shield
	6	-	-
	7	CAN_H	CAN_H bus line (dominant high)

CANopen Connector	Pin	Signal	Description
	8	-	-
	9	-	-
	-	CAN_SHLD	CAN shield

◆ **Option LED States**

Option has two LEDs that identify the option or communication status.

■ **Option LED Status Definitions**

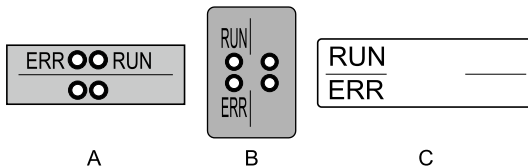

A - 1000-Series

C - FP605

B - GA500, GA700, GA800, LA700

Figure 4.2 Option LED Labels

Table 4.2 Option LED States

LED Name	Color	Display	Operating Status
RUN	Green	ON	Option operating
		Blinking	Pre-Operational State
		Single Flash	Stopped
		Flickering <i>* /</i>	Automatic bit rate detection in progress (alternately flickering with ERR LED)
ERR	Red	ON	Bus off
		Blinking	Bus initialization failed (parameter setting error)
		Single Flash	Fault has occurred/Receiving CAN error frame (too many error frames)
		Double Flash	Guard/Heartbeat event has occurred
		Flickering <i>* /</i>	Automatic bit rate detection in progress (alternately flickering with RUN LED)
		OFF	Online

*1 Available in option software version 3102 and later. Refer to the option package labeling in the field designated "PRG" (four digit number)" or the option labeling in the field designated "C/N" (S + four digit number)" to identify the option software version.

Figure 4.3 explains the indicator flash rates.

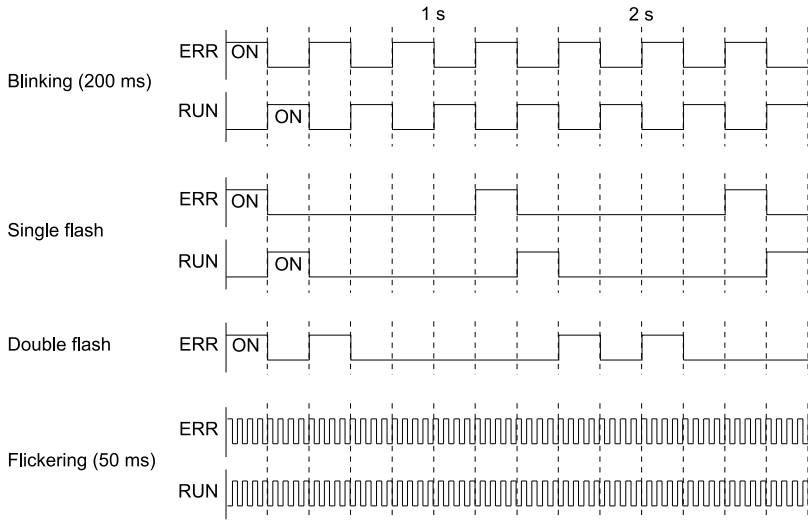

Figure 4.3 LED Flash Rates and Meaning

5 Installation Procedure

◆ Section Safety

⚠ DANGER *Electrical Shock Hazard. Do not examine, connect, or disconnect wiring on an energized drive. Before servicing, disconnect all power to the equipment and wait for the time specified on the warning label at a minimum. The internal capacitor stays charged after the drive is de-energized. The charge indicator LED extinguishes when the DC bus voltage decreases below 50 Vdc. When all indicators are OFF, measure for dangerous voltages to make sure that the drive is safe. If you do work on the drive when it is energized, it will cause serious injury or death from electrical shock.*

⚠ WARNING *Electrical Shock Hazard. Do not operate the drive when covers are missing. Replace covers and shields before you operate the drive. Use the drive only as specified by the instructions. Some figures in this section include drives without covers or safety shields to more clearly show the inside of the drive. If covers or safety shields are missing from the drive, it can cause serious injury or death.*

⚠ WARNING *Electrical Shock Hazard. Only let approved personnel install, wire, maintain, examine, replace parts, and repair the drive. If personnel are not approved, it can cause serious injury or death.*

⚠ WARNING *Electrical Shock Hazard. Do not remove covers or touch circuit boards while the drive is energized. If you touch the internal components of an energized drive, it can cause serious injury or death.*

⚠ WARNING *Electrical Shock Hazard. Do not use damaged wires, put too much force on the wiring, or cause damage to the wire insulation. Damaged wires can cause serious injury or death.*

⚠ WARNING *Fire Hazard. Tighten all terminal screws to the correct tightening torque. Connections that are too loose or too tight can cause incorrect operation and damage to the drive. Incorrect connections can also cause death or serious injury from fire.*

NOTICE *Damage to Equipment. When you touch the option, make sure that you observe correct electrostatic discharge (ESD) procedures. If you do not follow procedures, it can cause ESD damage to the drive circuitry.*

NOTICE *Damage to Equipment. Do not de-energize the drive while the drive is outputting voltage. Incorrect equipment sequencing can cause damage to the drive.*

NOTICE *Do not operate a drive or connected equipment that has damaged or missing parts. You can cause damage to the drive and connected equipment.*

NOTICE *Use Yaskawa connection cables or recommended cables only. Incorrect cables can cause the drive or option to function incorrectly.*

NOTICE *Damage to Equipment. Correctly connect the connectors. Incorrect connections can cause malfunction or damage to the equipment.*

NOTICE *Damage to Equipment. Make sure that all connections are correct after you install the drive and connecting peripheral devices. Incorrect connections can cause damage to the option.*

◆ Procedures to Install and Wire Options on a Drive

Procedures to install and wire the option are different for different drive models.

Refer to the following table to check the procedures to install and wire the option on a drive.

Table 5.1 Procedures to Install and Wire Options on a Drive

Product Series	Procedures to Install and Wire Options on a Drive	Page
A1000	Procedure A	17
U1000	Procedure A	17
U1000L	Procedure A	17
Z1000U	Procedure A	17
GA500	*J	-
GA700	Procedure B	22
GA800	Procedure B	22

Product Series	Procedures to Install and Wire Options on a Drive	Page
LA700	Procedure B	22
FP605	Procedure C	27

*1 To install the option on GA500 drives, use the option mounting kit (JOHB-GA50) and manual.

■ Procedure A

This section shows the procedure to install and wire the option on a 1000-series drive.

Prepare the Drive for the Option

Correctly wire the drive as specified by the manual packaged with the drive. Make sure that the drive functions correctly. Refer to the drive manuals for more information.

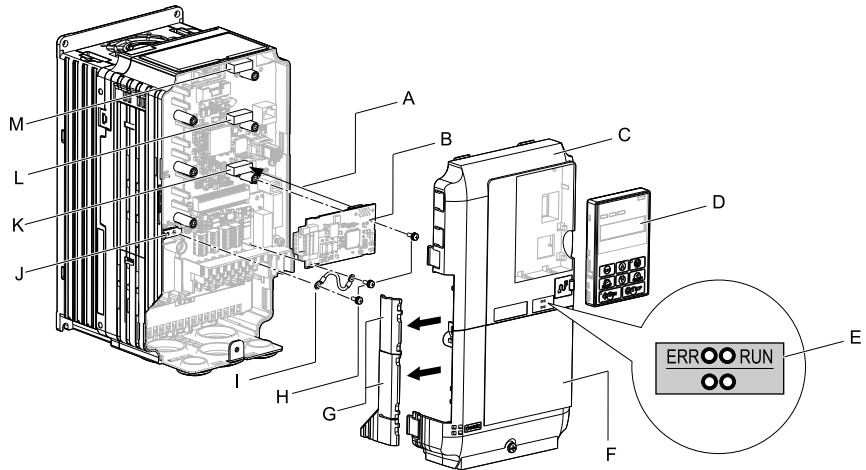

- | | |
|---------------------------------------|--|
| A - Insertion point for CN5 connector | H - Included screws |
| B - Option | I - Ground wire |
| C - Drive front cover | J - Drive grounding terminal (FE) |
| D - Keypad | K - Connector CN5-A |
| E - LED label | L - Connector CN5-B (Not available for communication option installation.) |
| F - Drive terminal cover | M - Connector CN5-C (Not available for communication option installation.) |
| G - Removable tabs for wire routing | |

Figure 5.1 Drive Components with Option

Install the Option

Use this procedure to install the option.

⚠ DANGER *Electrical Shock Hazard. Do not examine, connect, or disconnect wiring on an energized drive. Before servicing, disconnect all power to the equipment and wait for the time specified on the warning label at a minimum. The internal capacitor stays charged after the drive is de-energized. The charge indicator LED extinguishes when the DC bus voltage decreases below 50 Vdc. When all indicators are OFF, measure for dangerous voltages to make sure that the drive is safe. If you do work on the drive when it is energized, it will cause serious injury or death from electrical shock.*

1. Remove the keypad (B), front cover (A), and terminal cover (C).

Shut off power to the drive and wait for the time specified on the drive warning label at a minimum. Make sure that the charge indicator LED is unlit, then remove the keypad and front cover. Refer to the drive manuals for more information.

You can only install this option into the CN5-A connector on the drive control board.

NOTICE *Damage to Equipment. When you touch the option, make sure that you observe correct electrostatic discharge (ESD) procedures. If you do not follow procedures, it can cause ESD damage to the drive circuitry.*

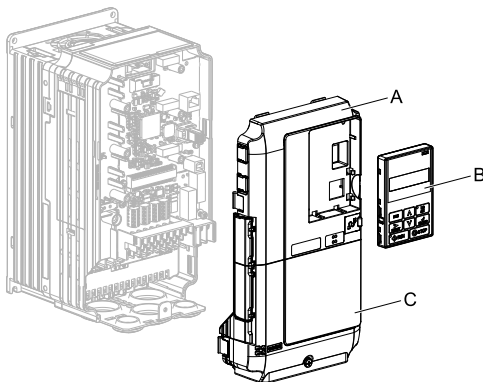

A - Drive front cover

C - Drive terminal cover

B - Keypad

Figure 5.2 Remove the Keypad, Front Cover, and Terminal Cover

- Put the LED label (B) in the correct position on the drive front cover (A).

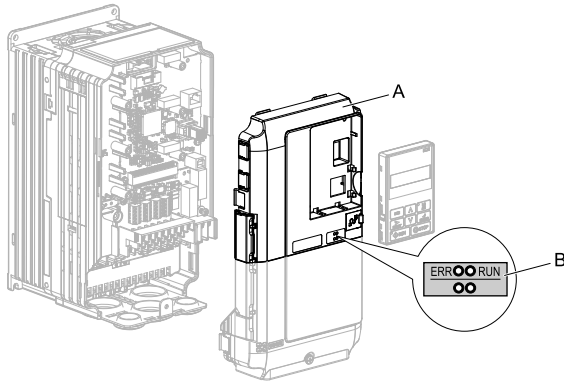

A - Drive front cover

B - LED label

Figure 5.3 Put the LED Label on the Drive Front Cover

- Install the option (A) into the CN5-A connector (C) on the drive and use one of the included screws (B) to put it in place.

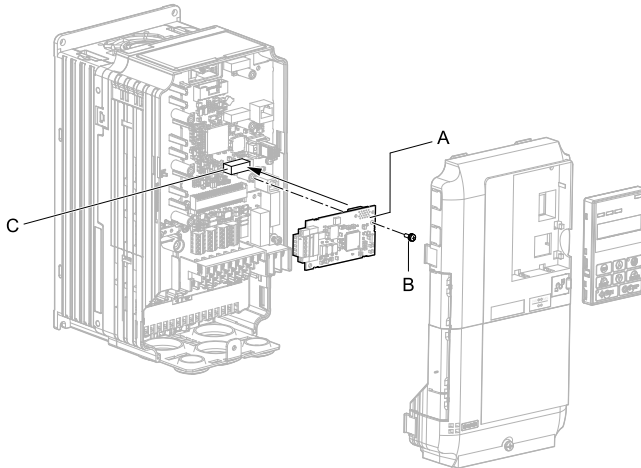

A - Option

B - Included screw

C - Connector CN5-A

Figure 5.4 Install the Option

4. Use one of the remaining included screws (B) to connect one end of the ground wire (C) to the ground terminal (D). Use the last remaining included screw (B) to connect the other end of the ground wire (C) to the remaining ground terminal and installation hole on the option (A).

Tighten the screws to a correct tightening torque:

- 0.5 N·m to 0.6 N·m (4.4 lbf·in to 5.3 lbf·in)

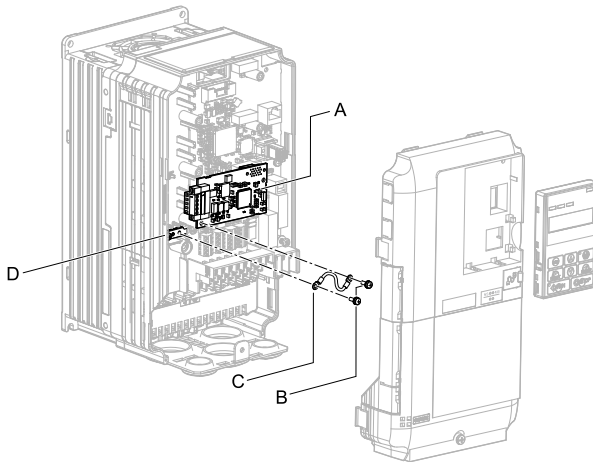

A - Option

B - Included screws

C - Ground wire

D - Drive grounding terminal (FE)

Figure 5.5 Connect the Ground Wire

Note:

The drive has only two ground terminal screw holes. When you connect three options, two options will share one ground terminal.

5. Route the option wiring.

Procedures to wire the option are different for different drive models.

- You can route the option wiring through openings on the front cover of some models. Remove the perforated tabs on the left side of the front cover as shown in [Figure 5.6-A](#) to create the necessary openings on these models. To prevent damage to the cable from the cut end, treat the cut surface with sandpaper.
- Route the option wiring inside the enclosure as shown in [Figure 5.6-B](#). Refer to the drive manuals for more information.

Note:

- Isolate communication cables from main circuit wiring and other electrical and power lines.

- Connect the terminator (model No.: JEPMC-W6022-E) to the option modular connector (CN3) on the end drive of the communication lines.

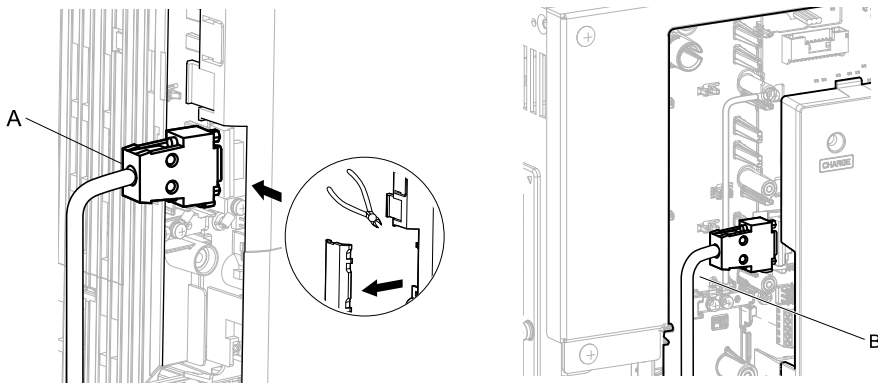

- A - Route wires through the openings provided on the left side of the front cover. ***
- B - Use the open space provided inside the drive to route option wiring.**

Figure 5.6 Wire Routing Examples

*1 If there is wiring outside the enclosure, the drive will not meet Enclosed wall-mounted type (IP20/UL Type 1) requirements.

6. Firmly connect the CANopen communication cable to option communication connector 9-pin D-sub.

Isolate communication cables from main circuit wiring and other electrical and power lines. Make sure that you firmly connect the cable end. (Refer to [Figure 5.22](#)). Refer to [Communication Cable Specifications on page 36](#) for more information.

Note:

Do not connect or disconnect the communication cable while the drive is energized or while the drive is in operation. Failure to obey can cause a static discharge, which will cause the option to stop working correctly. Cycle power on the drive and option to start using the option again.

7. Reattach the front cover (A), terminal cover (C), and keypad (B).

Refer to the drive manuals for more information.

NOTICE Do not pinch cables between the front covers and the drive. Failure to comply could cause erroneous operation.

NOTICE *Damage to Equipment.* When you touch the option, make sure that you observe correct electrostatic discharge (ESD) procedures. If you do not follow procedures, it can cause ESD damage to the drive circuitry.

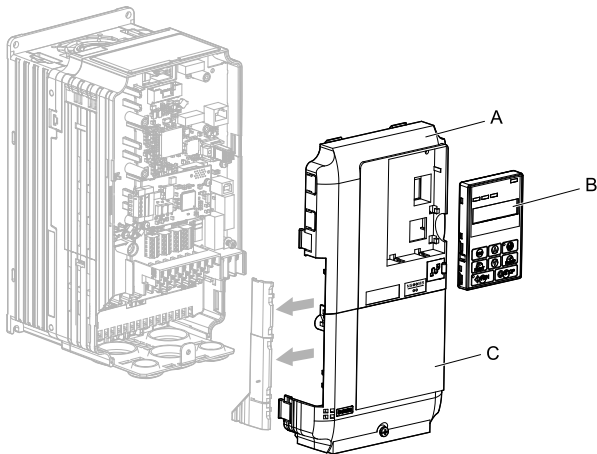

A - Drive front cover

B - Keypad

C - Drive terminal cover

Figure 5.7 Replace the Front Cover, Terminal Cover, and Keypad

8. Set drive parameters in [Related Drive Parameters on page 37](#) for correct option performance.

Make sure that you set *F6-35 [CANopen Node ID Selection]* to a node address that is unique on the network.

■ Procedure B

This section shows the procedure to install and wire the option on a GA700, GA800, or LA700 drive.

Prepare the Drive for the Option

Correctly wire the drive as specified by the manual packaged with the drive. Make sure that the drive functions correctly. Refer to the drive manuals for more information.

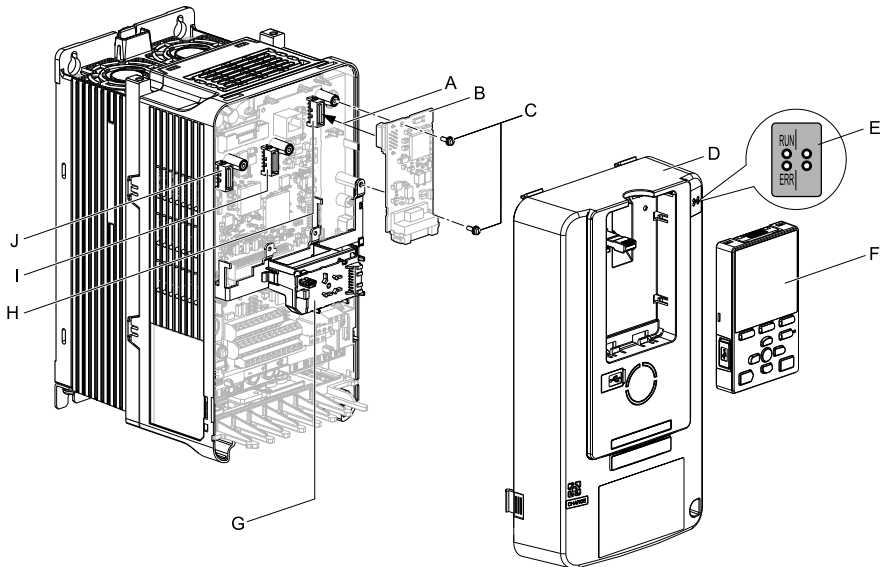

- | | |
|--|---|
| A - Insertion point for CN5 connector | F - Keypad |
| B - Option | G - LED Status Ring board |
| C - Included screws | H - Connector CN5-A |
| D - Drive front cover | I - Connector CN5-B (Not available for communication option installation.) |
| E - LED label | J - Connector CN5-C (Not available for communication option installation.) |

Figure 5.8 Drive Components with Option

Install the Option

Use this procedure to install the option.

⚠ DANGER *Electrical Shock Hazard. Do not examine, connect, or disconnect wiring on an energized drive. Before servicing, disconnect all power to the equipment and wait for the time specified on the warning label at a minimum. The internal capacitor stays charged after the drive is de-energized. The charge indicator LED extinguishes when the DC bus voltage decreases below 50 Vdc. When all indicators are OFF, measure for dangerous voltages to make sure that the drive is safe. If you do work on the drive when it is energized, it will cause serious injury or death from electrical shock.*

1. Put the LED label (A) in the correct position on the drive front cover (B).

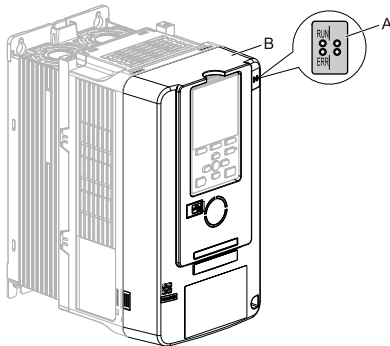

A - LED label

B - Drive front cover

Figure 5.9 Put the LED Label on the Drive Front Cover

2. Remove the keypad (E) and front cover (D).

Shut off power to the drive and wait for the time specified on the drive warning label at a minimum. Make sure that the charge indicator LED is unlit, then remove the keypad and front cover. Refer to the drive manuals for more information.

You can only install this option into the CN5-A connector on the drive control board.

NOTICE *Damage to Equipment.* When you touch the option, make sure that you observe correct electrostatic discharge (ESD) procedures. If you do not follow procedures, it can cause ESD damage to the drive circuitry.

Note:

Remove the keypad, then move the keypad connector to the holder on the drive, then remove the front cover.

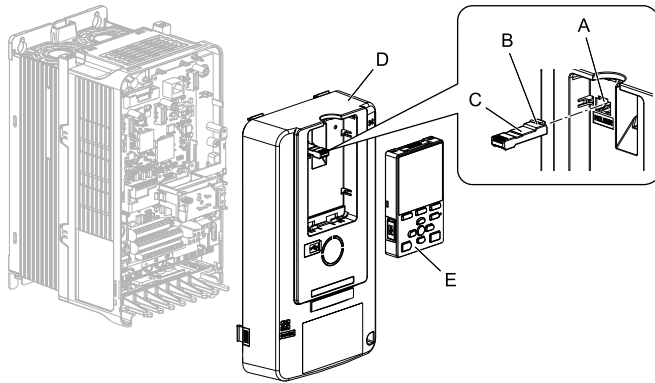

A - Holder

B - Keypad connector tab

C - Keypad connector

D - Drive front cover

E - Keypad

Figure 5.10 Remove the Front Cover and Keypad

- Carefully remove the LED Status Ring board (A) and put it in the temporary placement holes (B) on the right side of the drive. Refer to the drive manuals for more information.

NOTICE

Do not remove the LED Status Ring board cable connector. If you disconnect the LED Status Ring board, it can cause incorrect operation and damage to the drive.

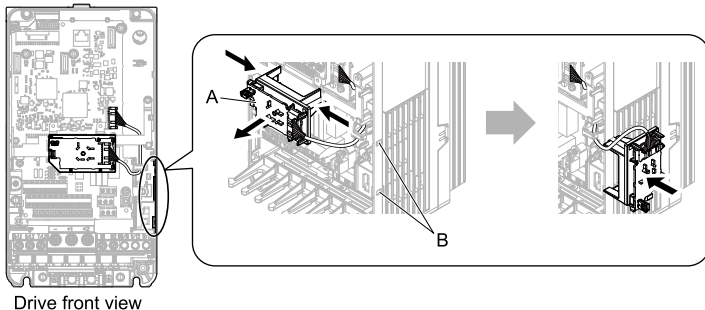

Drive front view

A - LED Status Ring board

B - Temporary placement holes

Figure 5.11 Remove the LED Status Ring Board

4. Install the option (A) into the CN5-A connector (C) on the drive and use the included screws (B) to put it in place.

Tighten the screws to a correct tightening torque:

- 0.5 N·m to 0.6 N·m (4.4 lbf-in to 5.3 lbf-in)

Note:

1. A ground wire is not necessary. Do not use the ground wire.
2. Only two screws are necessary to install the option on GA700, GA800, and LA700 drives.

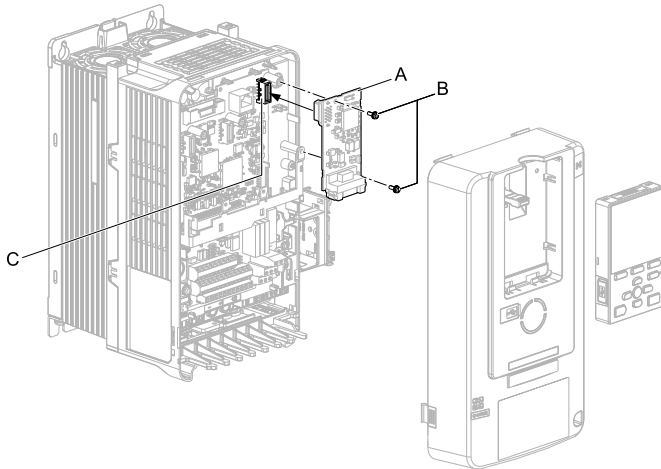

A - Option

C - Connector CN5-A

B - Included screws

Figure 5.12 Install the Option

5. Firmly connect the CANopen communication cable to option communication connector 9-pin D-sub.

Isolate communication cables from main circuit wiring and other electrical and power lines. Make sure that you firmly connect the cable end. (Refer to [Figure 5.22](#)). Refer to [Communication Cable Specifications on page 36](#) for more information.

NOTICE *Damage to Equipment.* When you touch the option, make sure that you observe correct electrostatic discharge (ESD) procedures. If you do not follow procedures, it can cause ESD damage to the drive circuitry.

6. Reattach the LED Status Ring board (E), front cover (C), and keypad (D). Refer to the drive manuals for more information.

NOTICE *Do not pinch cables between the front cover or the LED Status Ring board and the drive. Failure to comply could cause erroneous operation.*

Note:

- Replace the keypad connector, then install the keypad.
- Put the keypad connector tab into the holder when you install the keypad connector to the holder.

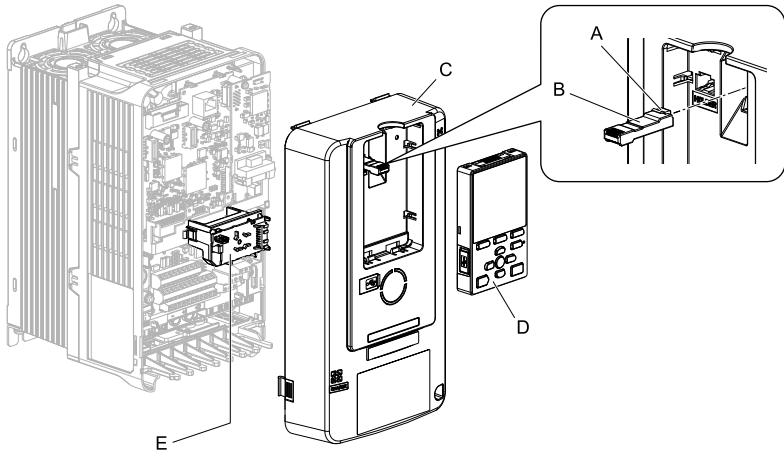

A - Keypad connector tab
 B - Keypad connector
 C - Drive front cover

D - Keypad
 E - LED Status Ring board

Figure 5.13 Install the LED Status Ring board, Front Cover, and Keypad

7. Set drive parameters in [Related Drive Parameters on page 37](#) for correct option performance.
 Make sure that you set *F6-35 [CANopen Node ID Selection]* to a node address that is unique on the network.

■ Procedure C

This section shows the procedure to install and wire the option on an FP605 drive.

Prepare the Drive for the Option

Correctly wire the drive as specified by the manual packaged with the drive. Make sure that the drive functions correctly. Refer to the drive manuals for more information.

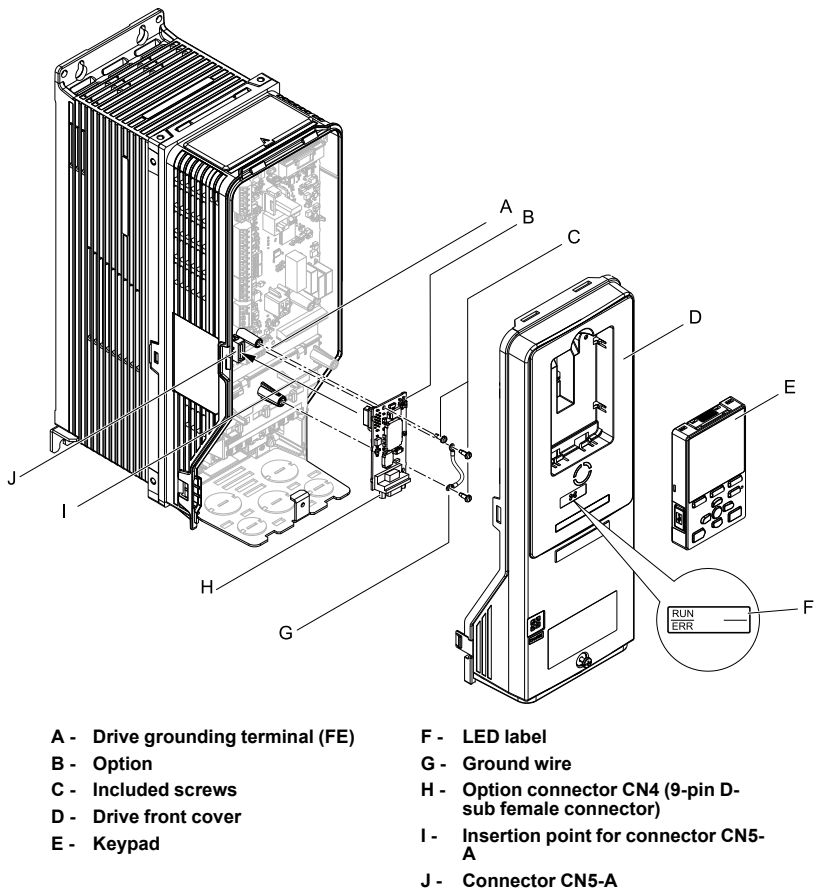

Figure 5.14 Drive Components with Option

Install the Option

Use this procedure to install the option.

⚠ DANGER *Electrical Shock Hazard. Do not examine, connect, or disconnect wiring on an energized drive. Before servicing, disconnect all power to the equipment and wait for the time specified on the warning label at a minimum. The internal capacitor stays charged after the drive is de-energized. The charge indicator LED extinguishes when the DC bus voltage decreases below 50 Vdc. When all indicators are OFF, measure for dangerous voltages to make sure that the drive is safe. If you do work on the drive when it is energized, it will cause serious injury or death from electrical shock.*

1. Remove the keypad (B) and front cover (A).

Shut off power to the drive and wait for the time specified on the drive warning label at a minimum. Make sure that the charge indicator LED is unlit, then remove the keypad and front cover. Refer to the drive manuals for more information.

NOTICE *Damage to Equipment.* When you touch the option, make sure that you observe correct electrostatic discharge (ESD) procedures. If you do not follow procedures, it can cause ESD damage to the drive circuitry.

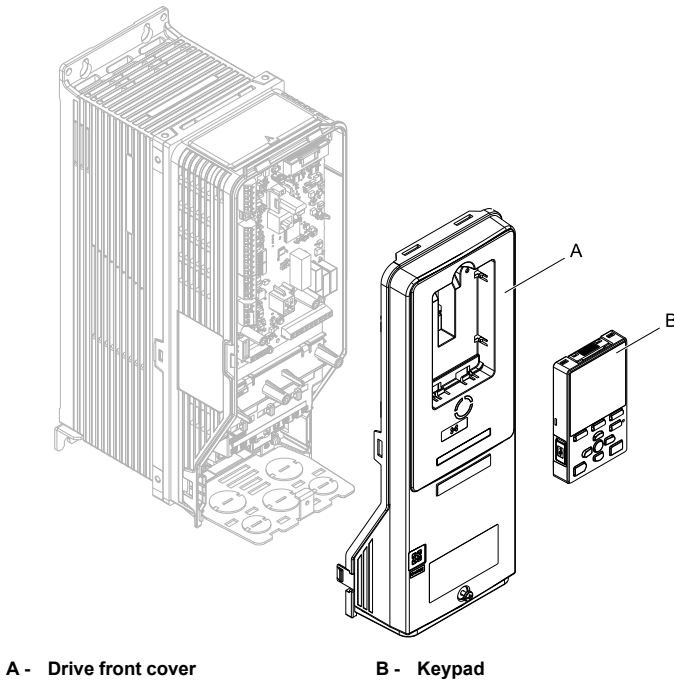
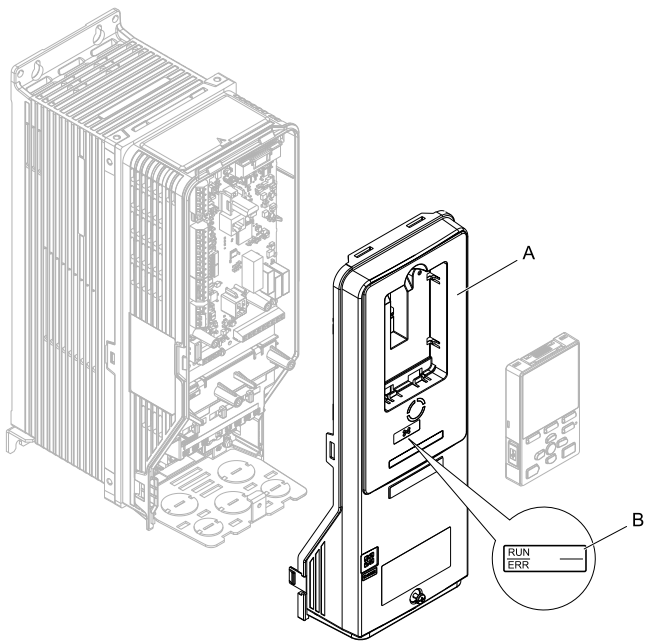

Figure 5.15 Remove the Front Cover and Keypad

- Put the LED label (B) in the correct position on the drive front cover (A).



A - Drive front cover

B - LED label

Figure 5.16 Put the LED Label on the Drive Front Cover

3. Remove the screw (B) installed in the drive grounding terminal (A).

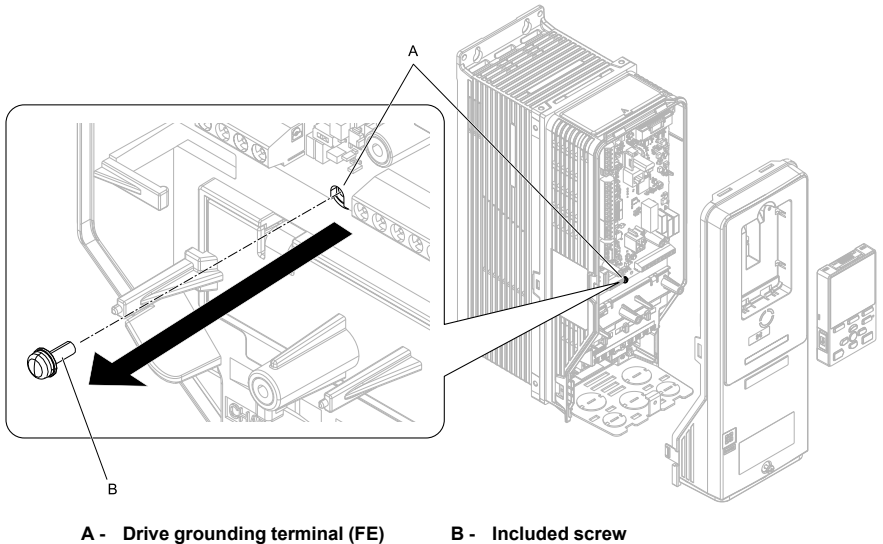
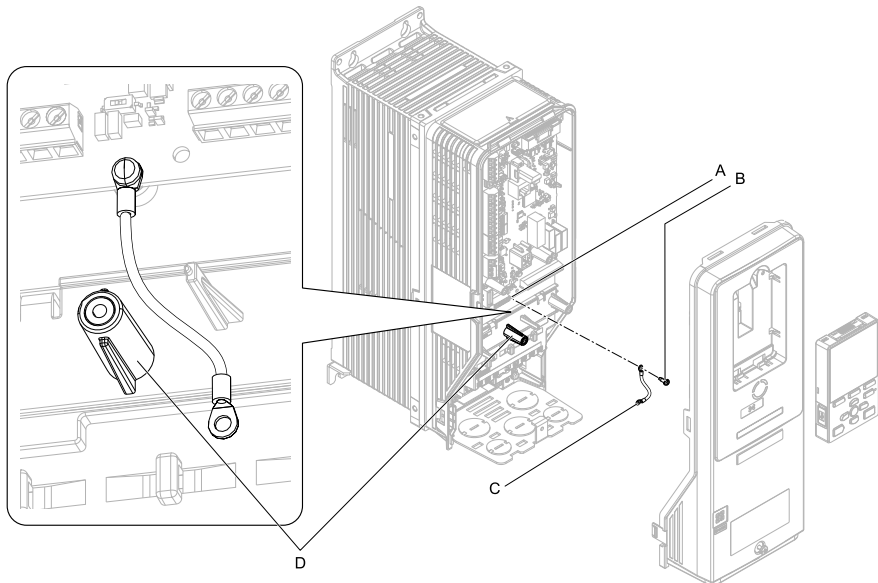

Figure 5.17 Remove the Screw from the Drive Grounding Terminal

4. Use the screw (B) installed in the FE ground terminal of the drive (A) to connect one end of the included ground wire (C) to the ground terminal on the drive.
Tighten the screw to a correct tightening torque:
 - 0.5 N·m to 0.6 N·m (4.4 lbf-in to 5.3 lbf-in)

Note:

Route ground wire on the right side of the stud (D).



A - Drive grounding terminal (FE)

B - Included screw

C - Ground wire

D - Stud

Figure 5.18 Connect the Ground Wire

5. Install the option (A) into the CN5-A connector (C) on the drive and use one of the included screws (B) to put it in place.

Tighten the screw to a correct tightening torque:

- 0.5 N·m to 0.6 N·m (4.4 lbf·in to 5.3 lbf·in)

Note:

1. Only two screws are necessary to install the option on an FP605 drive.
2. The option package contains three screws and one ground wire.

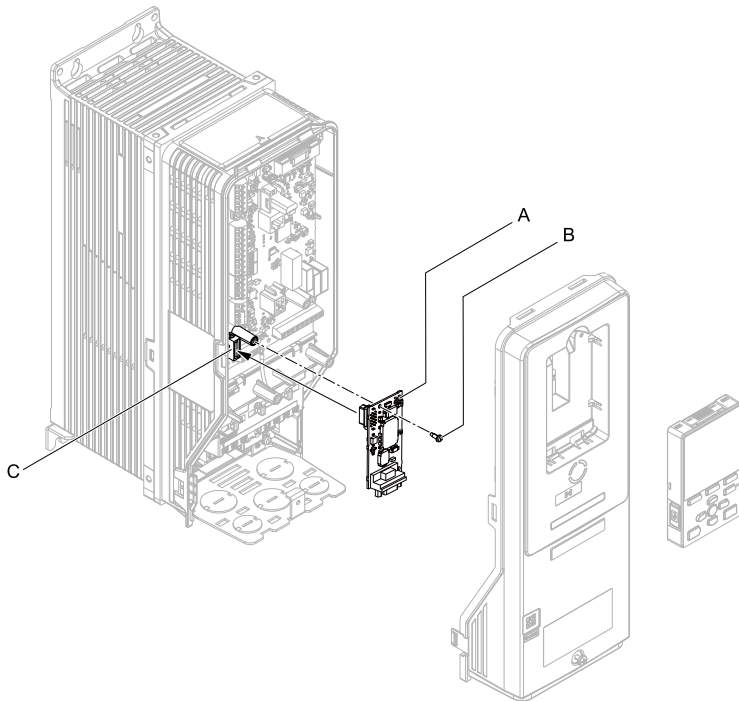

A - Option

B - Included screw

C - Connector CN5

Figure 5.19 Install the Option

6. Use one of the remaining included screws (B) to connect the ground wire (A) to the ground terminal and installation hole on the option.
Tighten the screw to a correct tightening torque:
 - 0.5 N·m to 0.6 N·m (4.4 lbf·in to 5.3 lbf·in)

Note:

Refer to [Figure 5.20](#) for instructions about crimp terminal orientation (C) and wire routing.

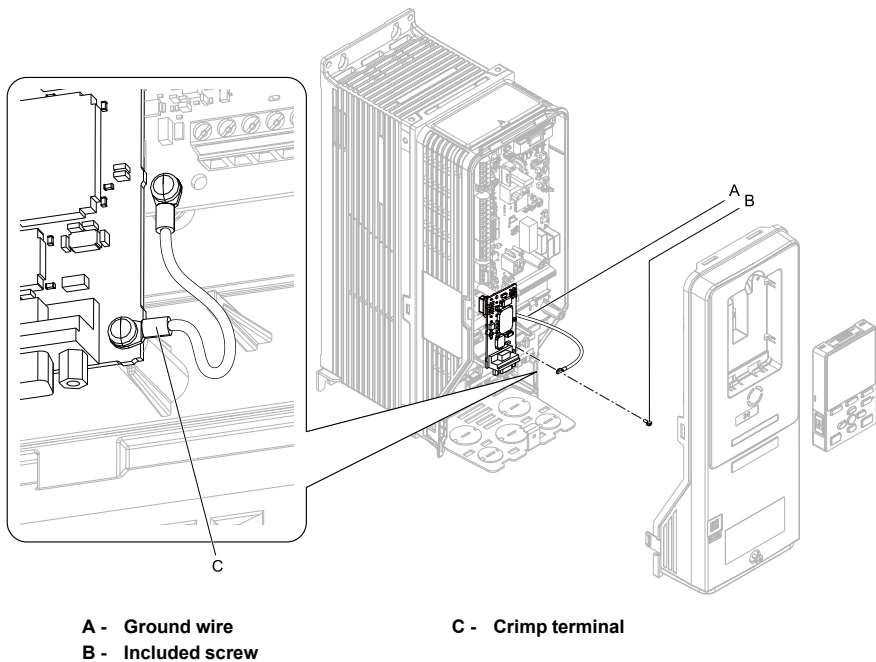

Figure 5.20 Connect the Ground Wire

7. Firmly connect the PROFIBUS-DP communication cable to the option 9-pin D-sub connector (CN4).

Isolate communication cables from main circuit wiring and other electrical and power lines. Make sure that you firmly connect the cable end. (Refer to [Figure 5.22](#)). Refer to [Communication Cable Specifications on page 36](#) for more information.

NOTICE *Damage to Equipment.* When you touch the option, make sure that you observe correct electrostatic discharge (ESD) procedures. If you do not follow procedures, it can cause ESD damage to the drive circuitry.

8. Reattach the drive front cover (A) and the keypad (B).

Refer to the drive manuals for more information.

NOTICE *Do not pinch cables between the front covers and the drive. Failure to comply could cause erroneous operation.*

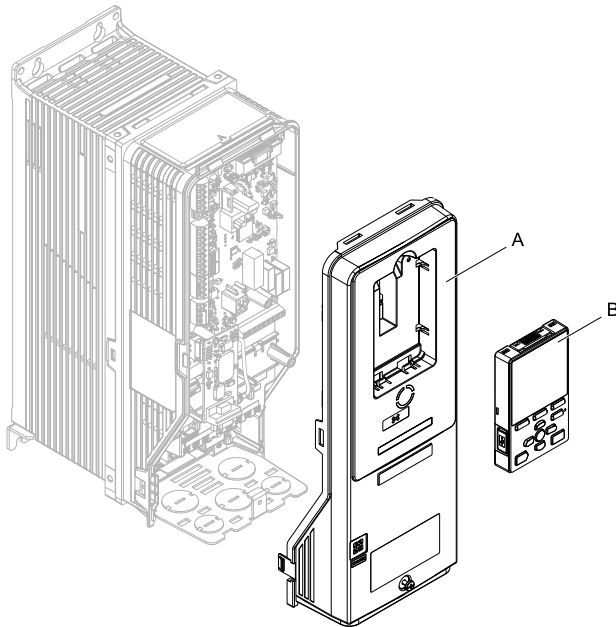

A - Drive front cover

B - Keypad

Figure 5.21 Replace the Front Cover and Keypad

9. Set drive parameters in [Related Drive Parameters on page 37](#) for correct option performance.
Make sure that you set *F6-35 [CANopen Node ID Selection]* to a node address that is unique on the network.

◆ Communication Cable Specifications

Use only CANopen dedicated communication cable; the Yaskawa warranty does not cover other cable types.

◆ Option Connection Diagram

You must connect the option to the network using a 9-pin D-sub connector wired as shown in [Figure 5.22](#).

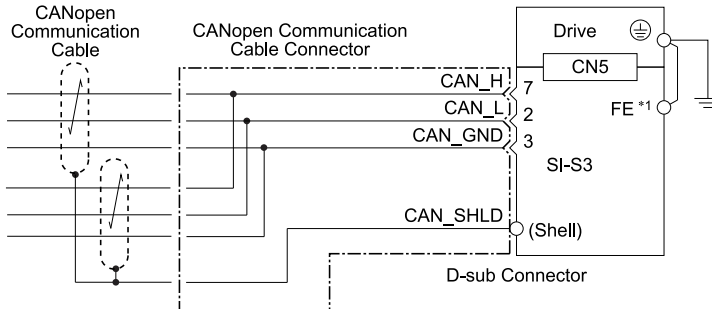

Figure 5.22 Option Connection Diagram

*1 Connect the included ground wire for installations on 1000-series, GA500, and FP605 drives. The ground wire is not necessary for installation on GA700, GA800, or LA700 drives.

◆ Termination Resistor Connection

Both ends of a CANopen network have to be terminated with a 120 Ω resistor. As the option has no build in termination resistor, make sure to apply a termination resistor as shown in [Figure 5.23](#) if the CANopen Option is the last node in the network.

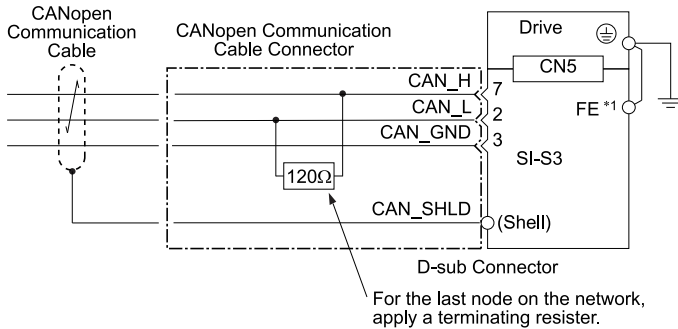

Figure 5.23 Termination Resistor Connection

- *1 Connect the included ground wire for installations on 1000-series, GA500, and FP605 drives. The ground wire is not necessary for installation on GA700, GA800, or LA700 drives.

◆ EDS Files

For easy network implementation of drives equipped with a CANopen Option, an EDS file can be obtained from:

U.S.: <http://www.yaskawa.com>

Europe: <http://www.yaskawa.eu.com>

Japan: <http://www.e-mechatronics.com>

Other areas: Check the back cover of these manuals.

For questions, contact Yaskawa or a Yaskawa representative.

You can download drive manuals from the Yaskawa product and technical information website shown on the back cover of this manual.

6 Related Drive Parameters

These parameters set the drive for operation with the option. Confirm correct parameter settings in this table before you start network communications.

Note:

Hex.: MEMOBUS addresses that you can use to change parameters over network communication are represented in hexadecimal numbers.

6 Related Drive Parameters

No. (Hex.)	Name	Description	Default (Range)
b1-01 (0180)	Frequency Reference Selection 1	Selects the input method for frequency reference. 0 : Keypad 1 : Analog Input 2 : Memobus/Modbus Communications 3 : Option PCB 4 : Pulse Train Input Note: <ul style="list-style-type: none"> • Set <i>b1-02 = 3</i> [<i>Run Command Selection 1 = Option PCB</i>] to use the master device and serial communications to start and stop the drive. Set <i>b1-01 = 3</i> to use the master device to control the frequency reference of the drive. • The default setting is different for different drives. Refer to the instruction manual of your specific drive for more information. 	1 (0 - 4)
b1-02 (0181)	Run Command Selection 1	Selects the input method for the Run command. 0 : Keypad 1 : Digital Input 2 : Memobus/Modbus Communications 3 : Option PCB Note: Set <i>b1-02 = 3</i> to start and stop the drive with the master device using serial communications. Set <i>b1-01 = 3</i> [<i>Frequency Reference Selection 1 = Option PCB</i>] to use the master device to control the frequency reference of the drive.	1 (0 - 3)
E2-04 (0311)	Motor Pole Count	Set the number of motor poles described on the motor nameplate. Note: <ul style="list-style-type: none"> • Relevant for DSP402. –1000-Series: 2 - 48 –GA500, GA700, GA800, LA700, FP605 2 - 120 • E2-04 is necessary to set up when the Drive Profile DSP 402 objects are used. 	4 (2 - 48)
F6-01 (03A2)	Communication Error Selection	Selects drive response when the drive detects a <i>bUS</i> [<i>Option Communication Error</i>] error during communications with the option. 0 : Ramp to Stop 1 : Coast to Stop 2 : Fast Stop (Use C1-09) 3 : Alarm Only 4 : Alarm - Run at d1-04 5 : Alarm - Ramp Stop	1 (0 - 5)

No. (Hex.)	Name	Description	Default (Range)
		<p>Note:</p> <ul style="list-style-type: none"> When you set this parameter to 3 or 4, the drive will continue operation after it detects a fault. Separately prepare safety protection equipment and systems, for example fast-stop switches. Refer to the drive manual to know if settings 4 and 5 are available. Settings 4 and 5 are available in A1000 software versions PRG: 1021 or later. The setting range for 1000-Series drives is different for different software versions. Refer to the Peripheral Devices & Options section of the drive instruction manual for more information. 	
F6-02 (03A3)	Comm External Fault (EF0) Detect	<p>Selects the conditions at which EF0 [Option Card External Fault] is detected.</p> <p>0 : Always Detected 1 : Detected during RUN Only</p>	0 (0, 1)
F6-03 (03A4)	Comm External Fault (EF0) Select	<p>Selects the operation of the drive when EF0 [Option Card External Fault] is detected.</p> <p>0 : Ramp to Stop 1 : Coast to Stop 2 : Fast Stop (Use C1-09) 3 : Alarm Only</p> <p>Note:</p> <p>When you set this parameter to 3, the drive will continue operation after it detects a fault. Separately prepare safety protection equipment and systems, for example fast stop switches.</p>	1 (0 - 3)
F6-06 (03A7)	Torque Reference/Limit by Comm	<p>Sets the function that enables and disables the torque reference and torque limit received from the communication option.</p> <p>0 : Disabled 1 : Enabled</p> <p>Note:</p> <ul style="list-style-type: none"> Control method availability of this parameter is different for different product series. <ul style="list-style-type: none"> 1000-Series Parameter is available in A1-02 = 3, 6, 7 [Control Method Selection = Closed Loop Vector; PM Advanced Open Loop Vector; PM Closed Loop Vector]. When you enable this parameter, d5-01 [Torque Control Selection] sets the drive to read the value as the Torque Limit value or the Torque Reference value. d5-01 = 0 [Torque Control Selection = Speed Control]: Torque Limit d5-01 = 1 [Torque Control Selection = Torque Control]: Torque Reference In A1-02 = 6, this value is read as the Torque Limit. <p>–GA500</p>	0 (0, 1)

No. (Hex.)	Name	Description	Default (Range)
		<p>Parameter is available in $A1-02 = 2, 6, 8$ [Control Method Selection = Open Loop Vector, PM Advanced Open Loop Vector, EZ Vector Control]. The drive reads this value as the Torque Limit.</p> <p>–GA700, GA800, LA700 Parameter is available in $A1-02 = 2, 3, 4, 6, 7, 8$ [Control Method Selection = Open Loop Vector, Closed Loop Vector, Advanced Open Loop Vector, PM Advanced Open Loop Vector, PM Closed Loop Vector, EZ Vector Control].</p> <p>When you enable this parameter, $d5-01$ [Torque Control Selection] sets the drive to read the value as the Torque Limit value or the Torque Reference value. $d5-01 = 0$ [Torque Control Selection = Speed Control]: Torque Limit $d5-01 = 1$ [Torque Control Selection = Torque Control]: Torque Reference In $A1-02 = 2, 8$, these values are read as the Torque Limit.</p> <p>–FP605 Torque Limit is enabled when $A1-02 = 8$ [Control Method Selection = EZ Vector Control].</p> <ul style="list-style-type: none"> If the PLC does not supply a torque reference or torque limit when $F6-06 = 1$ [Torque Reference/Limit by Comm = Enabled], the motor cannot rotate. 	
F6-07 (03A8)	Multi-Step Ref @ NetRef/ ComRef	<p>0 : Disable Multi-Step References 1 : Enable Multi-Step References</p> <p>Note: Default setting of $F6-07$ is 1 for GA500.</p>	0 (0, 1)
F6-08 (036A)	Comm Parameter Reset @Initialize	<p>Selects whether communication-related parameters $F6-xx$ and $F7-xx$ are set back to original default values when you use parameter $A1-03$ [Initialize Parameters] to initialize the drive.</p> <p>0 : No Reset - Parameters Retained 1 : Reset - Back to Factory Default</p> <p>Note: When you set $F6-08$ to 1 and you then use $A1-03$ to initialize the drive, the drive will not change this setting value.</p>	0 (0, 1)
F6-35 (03D0)	CANopen Node ID Selection	<p>Sets the node address for CANopen communication. Restart the drive after you change the parameter setting.</p> <p>Note: Be sure to set an address that is different than all other node addresses. Do not set this parameter to 0. Incorrect parameter settings will cause $A\text{Er}$ [Station Address Setting Error] errors and the L.ERR LED on the option will come on.</p>	0 (0 - 126)

No. (Hex.)	Name	Description	Default (Range)
F6-36 (03D1)	CANopen Communication Speed	Sets the CANopen communications speed. Restart the drive after you change the parameter setting. 0 : Auto-detection 1 : 10 kbps 2 : 20 kbps 3 : 50 kbps 4 : 125 kbps 5 : 250 kbps 6 : 500 kbps 7 : 800 kbps 8 : 1 Mbps	6 0 (0 - 8)
o1-03 (0502)	Frequency Display Unit Selection	Sets the display units for the frequency reference and output frequency. 0 : 0.01 Hz 1 : 0.01% (100% = E1-04) 2 : Revolutions Per Minute (RPM) 3 : User units (Set with o1-10, o1-11)	Determined by A1-02 (0 - 3)

7 Bit Rate and Node ID Setup

◆ Bit Rate Setup

In order to communicate with the drive, the bit rate set in the SI-S3 option must match the bit rate used in the network. The bit rate can be selected manually by using a drive parameter. The SI-S3 can also be set up for automatic bit rate detection.

■ Setting the Bit Rate Manually

Select the correct bit rate in *F6-36*. After changing *F6-36*, cycle the drive power supply to enable the changes.

Table 7.1 Bit Rate Setting

No.	Name	Description	Default
F6-36	CANopen Communication Speed	0: Auto-detection ^{*1} 1: 10 kbps 2: 20 kbps 3: 50 kbps 4: 125 kbps 5: 250 kbps 6: 500 kbps 7: 800 kbps 8: 1 Mbps	6

*1 Available in option software version 3102 and later.
Disabled in option software versions up to 3101.

■ Using Automatic Bit Rate Detection

Note:

Available in option software version 3102 and later.

Set $F6-36 = 0$ [*CANopen Communication Speed = Auto-detection*] to enable automatic bit rate detection and cycle the drive power supply. When set to automatic bit rate detection, after power up the option will listen to messages on the bus and adjust its bit rate setting automatically.

When the bit rate is found the option will enter pre-operational status and transmit a boot up message containing the drive's node ID. The option will not send any messages until the bit rate is detected.

As long as the automatic bit rate detection is in progress, the RUN and ERR LEDs on the option will flicker alternately.

Note:

- There must be bus traffic that the SI-S3 can listen to in order to detect the bit rate. If there is low traffic, the bit rate detection can take a long time.
- The bit rate detected by the SI-S3 is not automatically saved. When cycling the drive power supply, the SI-S3 will do bit rate detection again.
- In addition to the master, there must be at least one other node in the network that is set to the correct bit rate. For example, the bit rate cannot be detected if the network consists of a master that is set up for a certain bit rate (controller) and one or more drives with the option set to auto bit rate detection.

◆ Node ID Setup

The node ID can be set in $F6-35$. The value range is 1 to 126. Each node ID may only be used once in the network.

After changing $F6-35$, cycle the drive power supply to enable the changes.

Note:

When the node is set to 0, the ERR light will flash and "Aer" will appear on the drive keypad to indicate that an address setting error has occurred.

8 Communication Objects Overview

The following tables list up the communication objects supported by the CANopen option. For details about the object content, refer to the CANopen Option Technical Manual.

◆ Communication Profile Objects (DS 301)

Index (Hex.)	Name
1000	Device type
1001	Error register
1003	Pre-defined error field
1005	COB-ID SYNC message
1008	Manufacturer device name
1009	Manufacturer hardware version
100A	Manufacturer software version
100C	Guard time
100D	Life time factor
100E	Node guarding identifier
1010	Store parameters
1011	Restore default parameters
1014	COB-ID emergency object
1016	Consumer heartbeat time
1017	Producer heartbeat time
1018	Identity object

◆ Manufacturer Specific Profile Objects (DS 301)

Index (Hex.)	Name	
Input	2000	Operation Command
	2010	Speed Command
	2020	Torque Reference/Torque Limit
	2030	Torque Compensation
	2040	MEMOBUS/Modbus Read Command
	2050	MEMOBUS/Modbus Write Command
	2060	MEMOBUS/Modbus Unlimited Enter Command
	2070	MEMOBUS/Modbus Limited Enter Command ^{*1}
	2080 ^{*2}	Selectable (default: none)
	2090 ^{*2}	Selectable (default: none)
	20A0 ^{*2}	Selectable (default: none)
	20B0 ^{*2}	Selectable (default: none)
	20C0 ^{*2}	Selectable (default: none)
	3000 ^{*2}	Selectable (default: none)
	3100 ^{*2}	Selectable (default: none)
Output	2100	Drive Status
	2101 ^{*2}	Drive Status (Change of State filter support)
	2110	Output Frequency
	2111 ^{*2}	Output Frequency (Change of State filter support)
	2120	Output Current
	2121 ^{*2}	Output Current (Change of State filter support)
	2130	Torque Reference
	2131 ^{*2}	Output Torque (Change of State filter support)
	2140	MEMOBUS/Modbus Read Command Response
	2150	MEMOBUS/Modbus Write Command Response

Index (Hex.)	Name
2155 *2	PDO Parameter Write Response
2160	MEMOBUS/Modbus not limited enter command response
2180 *2	Selectable (default: Input terminal status)
2190 *2	Selectable (default: Analog input 1 monitor)
21A0 *2	Selectable (default: none)
21B0 *2	Selectable (default: none)
21C0 *2	Selectable (default: none)
21D0 *2	Selectable (default: none)
21E0 *2	Selectable (default: none)
21F0 *2	Selectable (default: none)
2200	Motor Speed *3
2201 *2	Motor Speed (Change of State filter support) *3

*1 The maximum number of times data can be written to the EEPROM used for the drive is 100,000 times. Do not use this write command frequently.

*2 Available in option software versions 3102 and later.

*3 Units for motor speed are determined by *o1-03*. If the control mode for the drive is set to PM Open Loop Vector Control (*A1-02* = 5), or if V/f control with simple PG feedback is disabled (*H6-01* ≠ 3) in V/f Control (*A1-02* = 0), the motor speed will be 0.

◆ Drives and Motion Profile Objects (DSP 402)

The drive supports the Drive and Motion Profile DSP 402 Velocity Mode. Before using the Velocity Mode objects the following parameters have to be set up in the drive. If these settings are not done properly, the Velocity Mode objects cannot be used or deliver wrong data.

- Motor Pole Count
 - *E2-04*
 - *E4-04* for motor 2
 - *E5-04* for PM motor
 - *E9-08* in EZ Open Loop Vector Control *1
- The frequency reference and output frequency display unit has to be set to min⁻¹ by setting parameter *o1-03* = 2 [*Frequency Display Unit Selection* = *Revolutions Per Minute (RPM)*].

*1 EZ Open Loop Vector Control is only available in GA500, GA700, GA800, LA700, and FP605 drives.

Object Type	Index (Hex.)	Name
Common Entries	60FD	Digital Inputs *1
	60FE	Digital Outputs *2
Device Control	6040	Controlword
	6041	Statusword
	6061	Modes of operation display
Velocity Mode	6042	v1 target velocity
	6043	v1 velocity demand
	6044	v1 control effort
	6046	v1 velocity min max amount
	6048	v1 velocity acceleration
	6049	v1 velocity deceleration
	604A	v1 velocity quick stop
	604C	v1 dimension factor
	604D	v1 pole number

*1 YASKAWA specifies this object as the drive digital output monitor. (Input from the network)

*2 YASKAWA specifies this object as the drive digital inputs. (Output to the network)

◆ PDOs and Default PDO Setup

The drive supports 15 Receive and 16 Transmit PDOs.

The tables below show the available PDOs, their default settings, and the objects that need to be set when changing the PDO configuration or the PDO mapping:

■ Receive PDOs (RxPDO)

PDO Number	Receive PDO Parameter		Receive PDO Mapping	
	COB-ID (Hex.)	Index (Hex.)	Mapped Objects (Hex.)	Index (Hex.)
1	200 + Node ID	1400	Subindex 1: 6040	1600
2	300 + Node ID	1401	Subindex 1: 6040 Subindex 2: 6060	1601

PDO Number	Receive PDO Parameter		Receive PDO Mapping	
	COB-ID (Hex.)	Index (Hex.)	Mapped Objects (Hex.)	Index (Hex.)
6	Not assigned	1405	Subindex 1: 6040 Subindex 2: 6042	1605
7	Not assigned	1406	Subindex 1: 6040 Subindex 2: 60FE sub1	1606
8	Not assigned	1407	Subindex 1: 6040 Subindex 2: 6060	1607
21	Not assigned	1414	Subindex 1: 6048 sub1 Subindex 2: 6048 sub2	1614
22	Not assigned	1415	Subindex 1: 6049 sub1 Subindex 2: 6049 sub2	1615
23	Not assigned	1416	Subindex 1: 604A sub1 Subindex 2: 604A sub2	1616
24	Not assigned	1417	Subindex 1: 604C sub1 Subindex 2: 604C sub2	1617
36	Not assigned	1423	Subindex 1: 2000	1623
37	Not assigned	1424	Subindex 1: 2010	1624
38	Not assigned	1425	Subindex 1: 2020	1625
39	Not assigned	1426	Subindex 1: 2030	1626
40	Not assigned	1427	Subindex 1: 2040 sub1	1627
41	Not assigned	1428	Subindex 1: 2050 sub1	1628

■ Transmit PDOs (TxPDO)

PDO Number	Transmit PDO Parameter		Transmit PDO Mapping	
	COB-ID (Hex.)	Index (Hex.)	Mapped Objects (Hex.)	Index (Hex.)
1	180 + Node ID	1800	Subindex 1: 6041	1A00
2	280 + Node ID	1801	Subindex 1: 6041 Subindex 2: 6061	1A01
6	Not assigned	1805	Subindex 1: 6041 Subindex 2: 6044	1A05
7	Not assigned	1806	Subindex 1: 6041	1A06

PDO Number	Transmit PDO Parameter		Transmit PDO Mapping	
	COB-ID (Hex.)	Index (Hex.)	Mapped Objects (Hex.)	Index (Hex.)
			Subindex 2: 60FD	
21	Not assigned	1814	Subindex 1: 6042	1A14
22	Not assigned	1815	Subindex 1: 6043	1A15
23	Not assigned	1816	Subindex 1: 6048 sub1 Subindex 2: 6048 sub2	1A16
24	Not assigned	1817	Subindex 1: 6049 sub1 Subindex 2: 6049 sub2	1A17
25	Not assigned	1818	Subindex 1: 604A sub1 Subindex 2: 604A sub2	1A18
26	Not assigned	1819	Subindex 1: 604C sub1 Subindex 2: 604C sub2	1A19
36	Not assigned	1823	Subindex 1: 2100	1A23
37	Not assigned	1824	Subindex 1: 2110	1A24
38	Not assigned	1825	Subindex 1: 2120	1A25
39	Not assigned	1826	Subindex 1: 2130	1A26
40	Not assigned	1827	Subindex 1: 2140 sub1	1A27
41	Not assigned	1828	Subindex 1: 2150 sub1	1A28

9 Troubleshooting

◆ Drive-Side Error Codes

Drive-side error codes appear on the drive keypad. The table below lists causes of the errors and possible corrective actions. Refer to the drive Technical Manual for additional error codes that may appear on the drive keypad.

■ Faults

Both *bUS* [Option Communication Error] and *EF0* [Option Card External Fault] can appear as a fault. When a fault occurs, the digital characters shown on the keypad does not flash but stay lit. The keypad ALM LED also stays lit. When an alarm occurs, the ALM LED flashes.

If communication stops while the drive is running, answer these questions to help fix the problem:

- Is the drive properly connected to the option? Is it loose?
- Is the communication line properly connected to the option? Is it loose?
- Is the PLC program working? Is the controller/PLC CPU stopped?
- Did a momentary power loss interrupt communications?

Code	Name	Causes	Possible Solutions
bUS	Option Communication Error	The drive did not receive a signal from the controller.	<ul style="list-style-type: none"> • Check for wiring errors. • Correct the wiring.
		The communications cable wiring is incorrect.	
		An existing short circuit or communications disconnection	Check disconnected cables and short circuits and repair as needed
		A data error occurred due to electric interference	<ul style="list-style-type: none"> • Prevent noise in the control circuit, main circuit, and ground wiring. • If you identify a magnetic contactor as a source of noise, install a surge absorber to the contactor coil. • Use only recommended cables or other shielded line. Ground the shield on the controller side or the drive input power side. • Separate all communication wiring from drive power lines. Install an EMC noise filter to the drive power supply input. • Counteract noise in the master controller (PLC).
		Option is damaged	If there are no problems with the wiring and the error continues to occur, replace the option.
	Connection Time-out	<ul style="list-style-type: none"> • The option Requested Packet Interval (RPI) timer timed out • Make sure that RPI time is set properly 	
EF0	Option Card External Fault	The option received an external fault from the controller.	<ol style="list-style-type: none"> 1. Find the device that caused the external fault and remove the cause. 2. Clear the external fault input from the controller.
		A programming error occurred on the controller side.	Examine the operation of the controller program.
oFA00	Option Not Compatible with Port	The option connected to connector CN5-A is not compatible.	<p>Connect the option to the correct connector.</p> <ul style="list-style-type: none"> • Use connector CN5-A when you connect the option. <p>To use other options, refer to those option manuals.</p>

Code	Name	Causes	Possible Solutions
oFA01	Option Card Fault (CN5-A)	The option connected to option port CN5-A was changed during run.	<ol style="list-style-type: none"> 1. De-energize the drive. 2. Connect the option to the correct option port.
oFA03, oFA04	Option Card Error (CN5-A)	A fault occurred in the option.	<ol style="list-style-type: none"> 1. De-energize the drive. 2. Make sure that the option is correctly connected to the connector. 3. If the problem continues, replace the option.
oFA30 to oFA43	Option Card Connection Error (CN5-A)	A fault occurred in the option.	<ol style="list-style-type: none"> 1. De-energize the drive. 2. Make sure that the option is correctly connected to the connector. 3. If the problem continues, replace the option.
oFb00	Option Not Compatible with Port	The option connected to connector CN5-B is not compatible.	<p>Connect the option to the correct connector.</p> <ul style="list-style-type: none"> • Use connector CN5-A when you connect the option. To use other options, refer to those option manuals.
oFb02	Option Fault	An option of the same type is already installed in option port CN5-A, CN5-B, or CN5-C.	Connect the option to the correct option port.
oFC00	Option Fault (CN5-B)	The option connected to connector CN5-C is not compatible.	<p>Connect the option to the correct connector.</p> <ul style="list-style-type: none"> • Use connector CN5-A when you connect the option. To use other options, refer to those option manuals.
oFC02	Option Fault	An option of the same type is already installed in option port CN5-A, CN5-B, or CN5-C.	Connect the option to the correct option port.
PE1	PLC Fault 1	The object dictionary settings were different from the settings stored in the EEPROM of the SI-S3, and Node Reset (NMT 81 (Hex.) xx (Hex.)) was performed while the drive was running.	<ul style="list-style-type: none"> • Stop the drive before performing Node Reset. • Save the object dictionary settings using Store Parameters (object 1010 (Hex.)) before performing Node Reset.

■ Minor Faults and Alarms

Code	Name	Causes	Possible Solutions
AEr	Station Address Error	CANopen Option is set to an address outside the allowable setting range.	Set <i>F6-35</i> to an address within the specified range.
CALL	Serial Comm Transmission Error	The communications cable wiring is incorrect.	Correct wiring errors.
		There is a short circuit in the communications cable or the communications cable is not connected.	<ul style="list-style-type: none"> Repair the short-circuited or disconnected portion of the cable. Replace the defective communications cable.
		A programming error occurred on the controller side.	Examine communications at start-up and correct programming errors.
		There is damage to the communications circuitry.	<ul style="list-style-type: none"> Do a self-diagnostics check. If the problem continues, replace the control board or the drive. Contact Yaskawa or your nearest sales representative to replace the control board.
		The termination resistor setting for MEMOBUS/Modbus communications is incorrect.	On the last drive in a MEMOBUS/Modbus network, set DIP switch S2 to the ON position to enable the termination resistor.
CyPo	Cycle Power to Active Parameters	Comm. Option Parameter Not Upgraded	<p>Re-energize the drive to update the communication option parameters.</p> <p>Note: If the option software version is not compatible or if you install an incorrect option to the drive, it will trigger an alarm.</p>
EEP	SI - S EEPROM Err	EEPROM checksum error	<p>If these errors occur, the object dictionary is reset to its default values.</p> <ul style="list-style-type: none"> After the object dictionary changes and object dictionary contents are changed, execute a Store Parameter command (Index = 1010 (Hex.)). If the object dictionary was not changed, execute a Restore Parameter command (Index = 1011 (Hex.)).

10 European Standards



Figure 10.1 CE Mark

The CE mark indicates compliance with European safety and environmental regulations. European standards include the Machinery Directive for machine manufacturers, the Low Voltage Directive for electronics manufacturers, and the EMC Directive for controlling noise.

It is required for engaging in business and commerce in Europe.

This option displays the CE mark based on the EMC Directive: 2014/30/EU.

Drives used in combination with this option and devices used in combination with the drive must also be CE certified and display the CE mark.

When using drives displaying the CE mark in combination with other devices, it is ultimately the responsibility of the user to ensure compliance with CE standards. Verify that conditions meet European standards after setting up the device.

◆ EMC Directive Compliance

This option is tested according to European standards EN 61800-3 and complies with EMC Directive. The CE marking is declared based on the harmonized standards.

■ Option Installation

Verify the following installation conditions to make sure that other devices and machinery used with this option and drive also comply with EMC Directive:

1. Use dedicated shielded cable for the option and external device (encoder, I/O device, master), or run the wiring through a metal conduit.

2. Keep wiring as short as possible and ground the largest possible surface area of the shield to the metal panel according to Figure 10.2, Figure 10.3, and Figure 10.4.

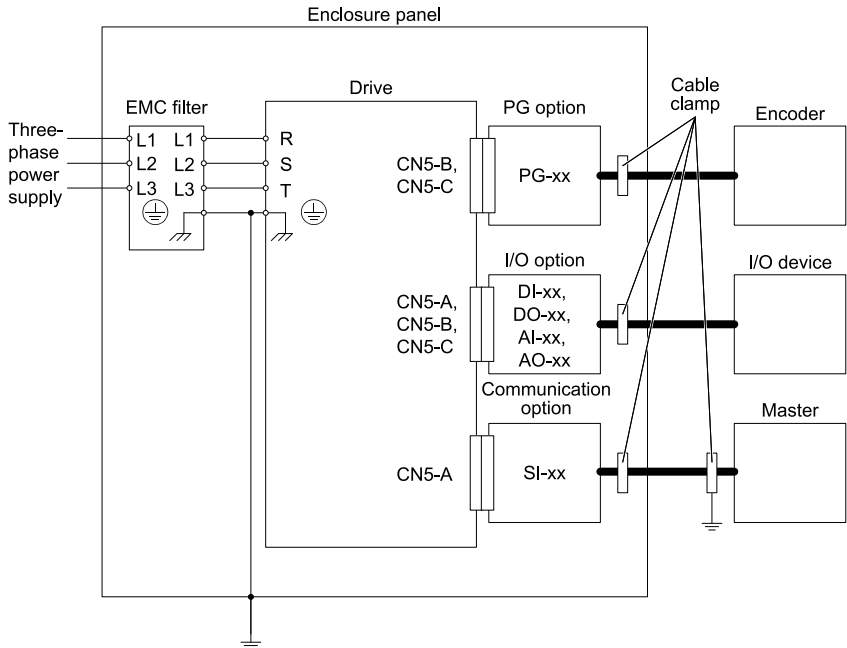

Figure 10.2 Option Installation for CE Compliance: 1000-Series, GA700, GA800, LA700

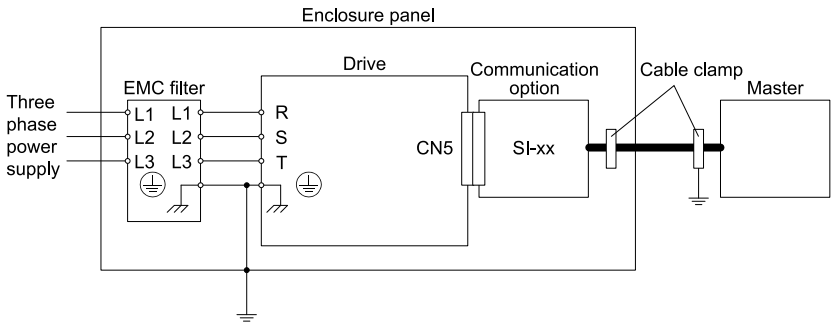

Figure 10.3 Option Installation for CE Compliance: GA500

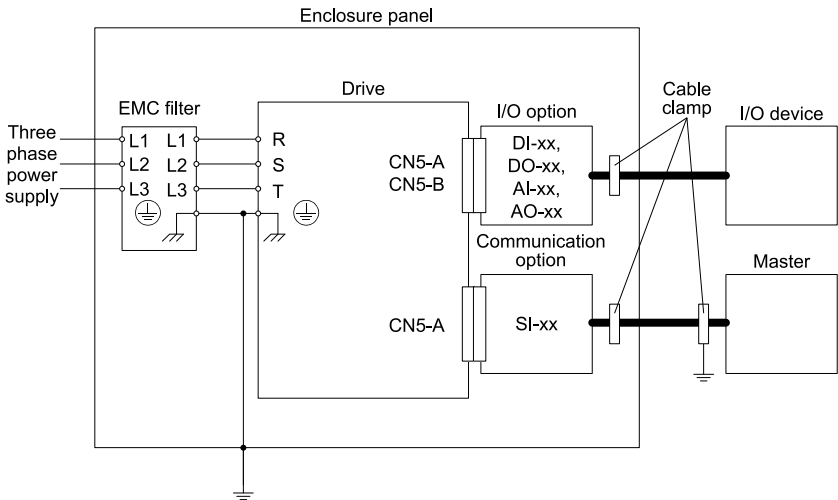

Figure 10.4 Option Installation for CE Compliance: FP605

3. Ground the largest possible surface area of the shield to the metal panel. Yaskawa recommends using cable clamps.

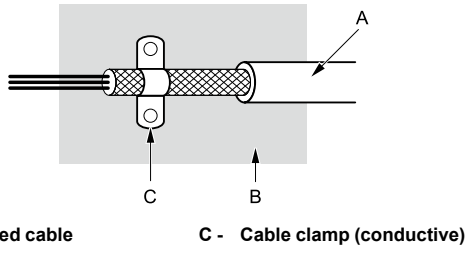

Figure 10.5 Ground Area

11 United Kingdom Conformity Assessed Marking



Figure 11.1 UKCA Mark

The UKCA mark indicates compliance with United Kingdom safety and environmental regulations.

It is required for engaging in business and commerce in the United Kingdom.

United Kingdom standards include the Supply of Machinery (Safety) Regulations (Machinery) for machine manufacturers, the Electrical Equipment (Safety) Regulations (Low voltage) for electronics manufacturers, and the Electromagnetic Compatibility Regulations (EMC) for controlling noise.

This product displays the UKCA mark in accordance with the EMC.

Table 11.1 Designated Standards

Statutory Instruments	Designated Standards
Electromagnetic Compatibility Regulations S.I. 2016 No. 1091	EN 61800-3 ^{*1}
Restriction of the Use of Certain Hazardous Substances in Electrical and Electronic Equipment Regulations S.I. 2012 No. 3032	EN IEC 63000 ^{*1}

*1 Refer to the "UK Declaration of Conformity" for the year of the Designated Standards.

When using drives displaying the UKCA mark in combination with other devices, it is ultimately the responsibility of the user to ensure compliance with UKCA standards. Verify that conditions meet applicable United Kingdom standards after setting up the device.

12 Korean Radio Waves Act



Figure 12.1 KC Mark

This product confirms to broadcast and communications equipment for business use (Class A) and are designed for use in locations other than in ordinary houses. Products that bear the Korea Certification (KC) mark conform to the Korean Radio Waves Act. Be careful when you use the drive in Korea under the following conditions.

Table 12.1 Precautions when Using This Product

Precautions
This equipment is evaluated for compatibility for use in a business environment and may cause radio interference in a domestic environment.

Note:

The user guide applies only to "Business Broadcasting Communication Equipment". Comply with the EMC Directive to conform to the Korean Radio Act.

13 Specifications

◆ Specifications

Table 13.1 Option Specifications

Items	Specifications
Model	SI-S3
Communication Profile	DS 301 Ver. 4.02 DSP 402 Ver. 1.1 Velocity Mode
Connector	9-pin D-sub connector (#4/40 UNC thread)

Items	Specifications
Communication Speed	10 kbps - 1 Mbps
Ambient Temperature	-10 °C to +50 °C (14 °F to 122 °F)
Humidity	95% RH or lower with no condensation
Storage Temperature	-20 °C to +60 °C (-4 °F to 140 °F) allowed for short-term transport of the product
Area of Use	Indoors and free from: <ul style="list-style-type: none"> • Oil mist, corrosive gas, flammable gas, and dust • Radioactive materials or flammable materials, including wood • Harmful gas or fluids • Salt • Direct sunlight • Falling foreign objects
Altitude	1000 m (3280 ft) or lower

14 Disposal

◆ Disposal Instructions

Correctly dispose of the product and packing material as specified by applicable regional, local, and municipal laws and regulations.

◆ WEEE Directive



The wheeled bin symbol on this product, its manual, or its packaging identifies that you must recycle it at the end of its product life.

You must discard the product at an applicable collection point for electrical and electronic equipment (EEE). Do not discard the product with usual waste.

Revision History

Date of Publication	Revision Number	Section	Revised Content
February 2026	2	Back cover	Revision: Address
September 2023	1	All	Addition: Information on LA700 Revision: Reviewed and corrected entire documentation
		Chapter 11	Addition: United Kingdom Conformity Assessed Marking
		Chapter 12	Addition: Korean Radio Waves Act
October 2022	-	-	First Edition This manual is created based on TOBP C730600 85D<4>-0.

YASKAWA AC Drive Option CANopen Installation Manual

DRIVE CENTER (INVERTER PLANT)

2-13-1, Nishimiyachi, Yukuhashi, Fukuoka,
824-8511, Japan
Phone: +81-930-25-2548 Fax: +81-930-25-3431
www.yaskawa.co.jp

YASKAWA ELECTRIC CORPORATION

New Pier Takeshiba South Tower, 1-16-1, Kaigan,
Minatoku, Tokyo, 105-6891, Japan
Phone: +81-3-5402-4502 Fax: +81-3-5402-4580
www.yaskawa.co.jp

YASKAWA AMERICA, INC.

2121, Norman Drive South, Waukegan, IL 60085, U.S.A.
Phone: +1-800-YASKAWA (927-5292) or +1-847-887-7000
Fax: +1-847-887-7310
www.yaskawa.com

YASKAWA ELÉTRICO DO BRASIL LTDA.

777, Avenida Piraporinha, Diadema, São Paulo,
09950-000, Brasil
Phone: +55-11-3585-1100 Fax: +55-11-3585-1187
www.yaskawa.com.br

YASKAWA EUROPE GmbH

Philipp-Reis-Str. 6, 65795 Hattersheim am Main, Germany
Phone: +49-6196-569-300
www.yaskawa.eu.com
E-mail: support@yaskawa.eu

YASKAWA ELECTRIC KOREA CORPORATION

6F, 112, LS-ro, Dongan-gu, Anyang-si, Gyeonggi-do, Korea
Phone: +82-31-8015-4224 Fax: +82-31-8015-5034
www.yaskawa.co.kr

YASKAWA ASIA PACIFIC PTE. LTD.

30A, Kallang Place, #06-01, 339213, Singapore
Phone: +65-6282-3003 Fax: +65-6289-3003
www.yaskawa.com.sg

YASKAWA ELECTRIC (THAILAND) CO., LTD.

59, 1F-5F, Flourish Building, Soi Ratchadapisek 18,
Ratchadapisek Road, Huaykwang, Bangkok, 10310,
Thailand
Phone: +66-2-017-0099 Fax: +66-2-017-0799
www.yaskawa.co.th

YASKAWA ELECTRIC (CHINA) CO., LTD.

22F, Link Square 1, No.222, Hubin Road, Shanghai,
200021, China
Phone: +86-21-5385-2200 Fax: +86-21-5385-3299
www.yaskawa.com.cn

YASKAWA ELECTRIC (CHINA) CO., LTD.

BEIJING OFFICE
Room 1011, Tower W3 Oriental Plaza, No. 1,
East Chang An Avenue,
Dong Cheng District, Beijing, 100738, China
Phone: +86-10-8518-4086 Fax: +86-10-8518-4082

YASKAWA ELECTRIC TAIWAN CORPORATION

12F, No. 207, Section 3, Beishin Road, Shindian District,
New Taipei City 23143, Taiwan
Phone: +886-2-8913-1333
Fax: +886-2-8913-1513 or +886-2-8913-1519
www.yaskawa.com.tw

YASKAWA INDIA PRIVATE LIMITED

#17/A, Electronics City, Hosur Road, Bengaluru,
560 100 (Karnataka), India
Phone: +91-80-4244-1900 Fax: +91-80-4244-1901
www.yaskawaindia.in

YASKAWA

YASKAWA ELECTRIC CORPORATION

In the event that the end user of this product is to be the military and said product is to be employed in any weapons systems or the manufacture thereof, the export will fall under the relevant regulations as stipulated in the Foreign Exchange and Foreign Trade Act. Therefore, be sure to follow all procedures and submit all relevant documentation according to any and all rules, regulations and laws that may apply.

Specifications are subject to change without notice for ongoing product modifications and improvements.

© 2022 YASKAWA ELECTRIC CORPORATION



TOEPC73060085

MANUAL NO. TOEP C730600 85B <2>-J0
Published in Japan February 2026
25-9-27
Original Instructions