

YASKAWA AC Drive Option **MECHATROLINK-III** Installation Manual

Model SI-ET3

To properly use the product, read this manual thoroughly and retain for easy reference, inspection, and maintenance. Ensure the end user receives this manual.

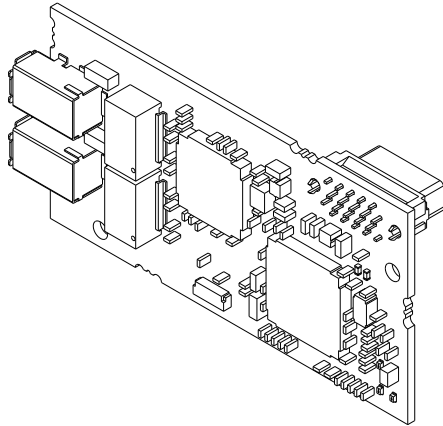

This Page Intentionally Blank

Table of Contents

1.	Preface and Safety	5
	Applicable Documentation	5
	Glossary	6
	Registered Trademarks	7
	Supplemental Safety Information	7
	Section Safety	7
2.	Overview	8
	Compatible Products	8
	Install the Option on a GA500 Drive	9
3.	Receiving	10
	Option Package Components	10
	Installation Tools	10
4.	Option Components	11
	Option	11
	Connector	11
	Option LED Display	12
	Option LED Status Definitions	12
5.	Installation Procedure	13
	Section Safety	13
	Procedures for Installing and Wiring Options on a Drive	14
	Procedure A	14
	Procedure B	21
	MECHATROLINK-III Communications Cables	26
	Option Connection Diagram	27
	Communication Cable Topology	27

6.	Related Drive Parameters	29
7.	Troubleshooting	33
	Drive-Side Error Codes	33
	Faults	33
	Minor Faults and Alarms	35
	Option Compatibility	36
8.	European Standards	37
	EMC Guidelines Compliance	37
	EMC Guidelines Installation Conditions	37
9.	Specifications	39
	Specifications	39
10.	Disposal	40
	Disposal Instructions	40
	WEEE Directive	41
	Revision History	42

1 Preface and Safety

YASKAWA Electric supplies component parts for use in a wide variety of industrial applications. The selection and application of YASKAWA products remain the responsibility of the equipment designer or end user.

YASKAWA accepts no responsibility for the way its products are incorporated into the final system design. Under no circumstances should any YASKAWA product be incorporated into any product or design as the exclusive or sole safety control. Without exception, all controls should be designed to detect faults dynamically and fail safely under all circumstances. All products designed to incorporate a component part manufactured by YASKAWA must be supplied to the end user with appropriate warnings and instructions as to the safe use and operation of that part. Any warnings provided by YASKAWA must be promptly provided to the end user. YASKAWA offers an express warranty only as to the quality of its products in conforming to standards and specifications published in the manual. **NO OTHER WARRANTY, EXPRESS OR IMPLIED, IS OFFERED.** YASKAWA assumes no liability for any personal injury, property damage, losses, or claims arising from misapplication of its products.

◆ Applicable Documentation

The following manuals are available for the option:

Document	Description
YASKAWA AC Drive Option MECHATROLINK-III Installation Manual Manual No.: TOBP C730600 88 (This book)	This guide is packaged together with the product and contains information necessary to install the option and set related drive parameters.
YASKAWA AC Drive Option MECHATROLINK-III Technical Manual Manual No.: SIEP C730600 88	The technical manual contains detailed information about the option. Access the following sites to obtain the technical manual: U.S.: http://www.yaskawa.com Europe: http://www.yaskawa.eu.com Japan: http://www.e-mechatronics.com Other areas: Check the back cover of these manuals. For questions, contact Yaskawa or a Yaskawa representative.
YASKAWA AC Drive Manuals	Drive manuals contain basic installation and wiring information in addition to detailed parameter setting, fault diagnostic, and maintenance information. The most recent versions of these manuals are available for download on our documentation websites: U.S.: http://www.yaskawa.com Europe: http://www.yaskawa.eu.com Japan: http://www.e-mechatronics.com Other areas: Check the back cover of these manuals. For questions, contact Yaskawa or a Yaskawa representative.

◆ Glossary

Phrase	Definition
Option	YASKAWA AC Drive Option MECHATROLINK-III
Keypad	<ul style="list-style-type: none"> • LCD Operator for YASKAWA AC Drive 1000-Series • LED Operator for YASKAWA AC Drive 1000-Series • LCD Keypad for YASKAWA AC Drive GA500, GA700, GA800, CR700, and CH700 • LED Keypad for YASKAWA AC Drive GA500, GA700, GA800, CR700, and CH700
Drive	<ul style="list-style-type: none"> • YASKAWA AC Drive 1000-Series (A1000, U1000, Z1000U) • YASKAWA AC Drive GA500 • YASKAWA AC Drive GA700 • YASKAWA AC Drive GA800 • YASKAWA AC Drive CR700 • YASKAWA AC Drive CH700
Hex. (Example: 900 (Hex.))	Indicates a unit for hexadecimal number format.

◆ Registered Trademarks

- MECHATROLINK-III is a trademark of the MECHATROLINK Members Association (MMA).
- All trademarks are the property of their respective owners.

◆ Supplemental Safety Information

Read and understand this manual before installing, operating, or servicing this option. The option must be installed according to this manual and local codes.

The following conventions are used to indicate safety messages in this manual. Failure to heed these messages could result in serious or possibly even fatal injury or damage to the products or to related equipment and systems.

▲ DANGER *This signal word identifies a hazard that will cause serious injury or death if you do not prevent it.*

▲ WARNING *This signal word identifies a hazard that can cause death or serious injuries if you do not prevent it.*

▲ CAUTION *Identifies a hazardous situation, which, if not avoided, can cause minor or moderate injury.*

NOTICE *This signal word identifies a property damage message that is not related to personal injury.*

■ Section Safety

General Precautions

- The diagrams in this section may include options and drives without covers or safety shields to illustrate details. Be sure to reinstall covers or shields before operating any devices. The option should be used according to the instructions described in this manual.
- The diagrams in this manual are provided as examples only and may not pertain to all products covered by this manual.
- The products and specifications described in this manual or the content and presentation of the manual may be changed without notice to improve the product and/or the manual.
- Contact Yaskawa or a Yaskawa representative and provide the manual number shown on the front cover to order new copies of the manual.

▲ DANGER *Do not ignore the safety messages in this manual. If you ignore the safety messages in this manual, it will cause serious injury or death. The manufacturer is not responsible for injuries or damage to equipment.*

▲ WARNING *Electrical Shock Hazard. Do not modify the body or circuitry of drive or option. Failure to obey can cause damage to the drive and will void warranty. Yaskawa is not responsible for modifications of the product made by the user.*

NOTICE *Do not use steam or other disinfectants to fumigate wood for packaging the drive. Use alternative methods, for example heat treatment, before you package the components. Gas from wood packaging fumigated with halogen disinfectants, for example fluorine, chlorine, bromine, iodine or DOP gas (phthalic acid ester), can cause damage to the drive.*

2 Overview

The option provides a communications connection between the drive and a MECHATROLINK-III network. The option connects the drive to a MECHATROLINK-III network and facilitates the exchange of data.

Install the option on a drive to perform the following functions from a MECHATROLINK-III master device:

- Operate the drive
- Monitor the drive operation status
- Change drive parameter settings

◆ Compatible Products

You can use the option with the products in the following table:

Table 2.1 Compatible Products

Product Series	Model (s)	Software Version ^{*1}
A1000	CIMR-Ax2Axxxx	≥1020
	CIMR-Ax4A0002 - 4A0675	
	CIMR-Ax4A0930, 4A1200	≥3015
	CIMR-Ax5Axxxx	≥5040 ≥1020
U1000	CIMR-UxxAxxxx	≥1010
	CIMR-UxxExxxx	
	CIMR-UxxPxxxx	
	CIMR-UxxWxxxx	
Z1000U	CIMR-ZxxAxxxx	≥6110
	CIMR-ZxxExxxx	
	CIMR-ZxxPxxxx	
	CIMR-ZxxWxxxx	
GA500 ^{*2}	CIPR-GA50xxxxx	≥1010
GA700 ^{*2}	CIPR-GA70xxxxx	≥1010
GA800 ^{*2}	CIPR-GA80xxxxx	≥9010

Product Series	Model (s)	Software Version ^{*/}
CR700 ^{*2}	CIPR-CR70xxxx	≥1012
CH700 ^{*2}	CIPR-CH70xxxx	≥1012

*1 Refer to "PRG" on the drive nameplate for the software version number.

*2 Before you install the option on a YASKAWA AC Drive GA500, GA700, GA800, CR700, or CH700, make sure that the option software version is PRG: 6202 or later.

Note:

Refer to the option package labeling in the field designated "PRG (four digit number)" or the option labeling in the field designated "C/N (S + four digit number)" to identify the option software version.

◆ Install the Option on a GA500 Drive

An option card mounting kit is necessary to install the option on a GA500 drive. The option card mounting kit model is JOHB-GA50. This kit is sold separately.

Refer to the option card mounting kit manual for more information about installation.

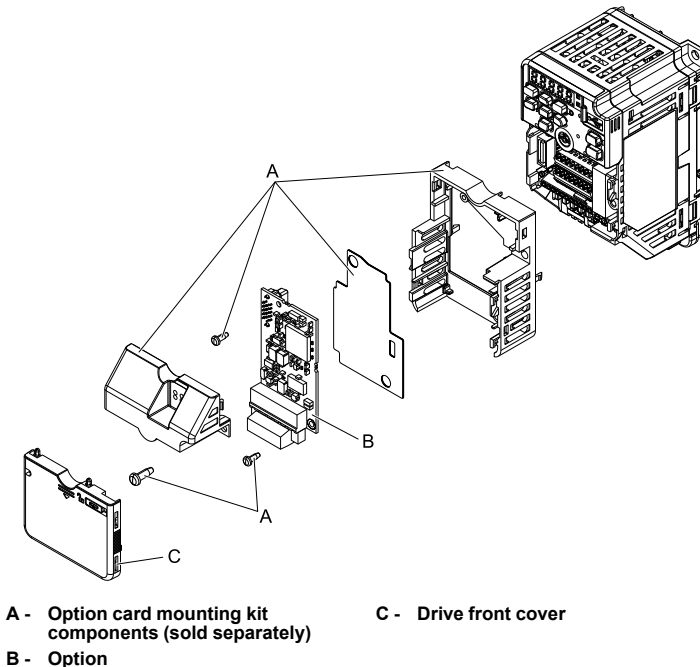

Figure 2.1 Option Card Mounting Kit (JOHB-GA50)

3 Receiving

After receiving the option package:

- Make sure that the option is not damaged and no parts are missing.
The Yaskawa warranty does not include damage from shipping. Contact your sales outlet if there is damage to the option or other parts.





NOTICE

Damage to Equipment. Do not use damaged parts to connect the drive and the option. Failure to comply could damage the drive and option.

- Confirm that the model number on the option nameplate and the model listed in the purchase order are the same. Refer to [Figure 4.1](#) for more information.
- Contact the distributor where the option was purchased or contact Yaskawa or a Yaskawa representative about any problems with the option.

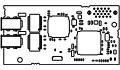
◆ Option Package Components

Table 3.1 Option Package Contents

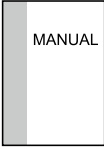
Description:	Option	Ground Wire <i>*1</i>	Screws (M3)	LED labels		Installation Manual
				1000-Series	GA500, GA700, GA800, CR700, and CH700	
-						
Quantity:	1	1	3 <i>*2</i>	1	1	1

*1 GA700, GA800, CR700, and CH700 drives do not use the ground wire.

*2 GA700, GA800, CR700, and CH700 drives use two screws only.

◆ Installation Tools

- A Phillips screwdriver or slotted screwdriver (blade depth: 0.4 mm (0.02 in), width: 2.5 mm (0.1 in)) **1*.
- A pair of diagonal cutting pliers.
- A small file or medium-grit sandpaper.

*1 Phillips screw sizes are different for different drive capacities.

4 Option Components

◆ Option

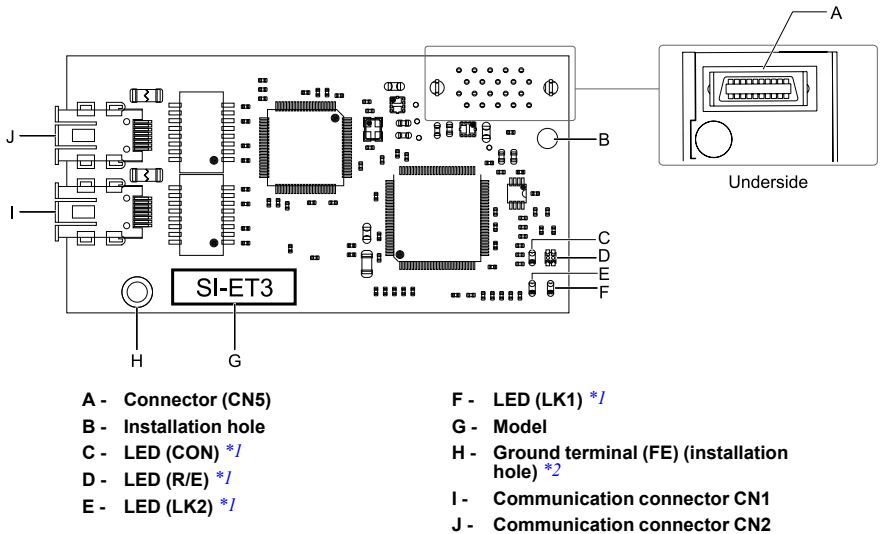

Figure 4.1 Option

*1 Refer to [Option LED Display on page 12](#) for more information about the LEDs.

*2 Connect the provided ground wire during installation. The ground wire is not necessary for installation on GA700, GA800, CR700, and CH700 drives.

◆ Connector

Table 4.1 Communication Connector

Connector	Pin No.	Signal Name	I/O	Function
	1	TXD_P	I/O	Send data (+): OUT
	2	TXD_N	I/O	Send data (-): OUT
	3	RXD_P	I/O	Receive data (+): IN
	4	(NC)	-	-
	5	(NC)	-	-
	6	RXD_N	I/O	Receive data (-): IN

Connector	Pin No.	Signal Name	I/O	Function
	7	(NC)	-	-
	8	(NC)	-	-
	Shell	SLD	-	Shield

◆ Option LED Display

Option has four LEDs that identify the option or communication status.

■ Option LED Status Definitions

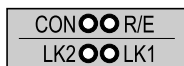

A

A - 1000-Series Label



B

B - GA500, GA700, GA800, CR700, and CH700 Label

Figure 4.2 Option LED Labels

Table 4.2 Option Operation LED Status

LED	State	Status	Description
R/E	Lit in green	Power supply on	<ul style="list-style-type: none"> The SI-ET3 has power and is prepared for operation An internal, self-diagnostic check completed in the option
	Lit in red	Error	<ul style="list-style-type: none"> Error/alarm occurred Command error occurred (parameter error, phase error, combination error)
	Flashing in red	SI-ET3 error	Error found during the SI-ET3 self-diagnostic check
	Unlit	Power supply off	<ul style="list-style-type: none"> The drive has no power The SI-ET3 is not properly connected to the drive, or the SI-ET3 has no power An internal, self-diagnostic error occurred in the SI-ET3
CON	Lit in green	Connection established	Established connection
	Unlit	Connection unestablished	Connection with master device is not established

LED	State	Status	Description
LK1	Lit in green	Connector CN1 connected	Connector CN1 is connected to other stations
	Unlit	Connector CN1 disconnected	Connector CN1 is not connected to other stations (cable not connected, cable disconnected, other stations not powered up)
LK2	Lit in green	Connector CN2 connected	Connector CN2 is connected to other stations
	Unlit	Connector CN2 disconnected	Connector CN2 is not connected to other stations (cable not connected, cable disconnected, other stations not powered up)

5 Installation Procedure

◆ Section Safety

▲ DANGER *Electrical Shock Hazard. Do not examine, connect, or disconnect wiring on an energized drive. Before servicing, disconnect all power to the equipment and wait for the time specified on the warning label at a minimum. The internal capacitor stays charged after the drive is de-energized. The charge indicator LED extinguishes when the DC bus voltage decreases below 50 Vdc. When all indicators are OFF, measure for dangerous voltages to make sure that the drive is safe. If you do work on the drive when it is energized, it will cause serious injury or death from electrical shock.*

▲ WARNING *Electrical Shock Hazard. Do not operate the drive when covers are missing. Replace covers and shields before you operate the drive. Use the drive only as specified by the instructions. Some figures in this section include drives without covers or safety shields to more clearly show the inside of the drive. If covers or safety shields are missing from the drive, it can cause serious injury or death.*

▲ WARNING *Electrical Shock Hazard. Only let approved personnel install, wire, maintain, examine, replace parts, and repair the drive. If personnel are not approved, it can cause serious injury or death.*

▲ WARNING *Electrical Shock Hazard. Do not remove covers or touch circuit boards while the drive is energized. If you touch the internal components of an energized drive, it can cause serious injury or death.*

▲ WARNING *Electrical Shock Hazard. Do not use damaged wires, put too much force on the wiring, or cause damage to the wire insulation. Damaged wires can cause serious injury or death.*

▲ WARNING *Fire Hazard. Tighten all terminal screws to the correct tightening torque. Connections that are too loose or too tight can cause incorrect operation and damage to the drive. Incorrect connections can also cause death or serious injury from fire.*

NOTICE *Observe correct electrostatic discharge (ESD) procedures when touching the option. Failure to obey can cause ESD damage to the option circuitry.*

NOTICE *Damage to Equipment. Do not de-energize the drive while the drive is outputting voltage. Incorrect equipment sequencing can cause damage to the drive.*

NOTICE

Do not operate a drive or connected equipment that has damaged or missing parts. You can cause damage to the drive and connected equipment.

NOTICE

Use Yaskawa connection cables or recommended cables only. Incorrect cables can cause the drive or option to function incorrectly.

NOTICE

Damage to Equipment. Correctly connect the connectors. Incorrect connections can cause malfunction or damage to the equipment.

NOTICE

Damage to Equipment. Make sure that all connections are correct after you install the drive and connecting peripheral devices. Incorrect connections can cause damage to the option.

◆ Procedures for Installing and Wiring Options on a Drive

Procedures to install and wire the option are different for different drive models.

Refer to the following table to check the procedures to install and wire the option on a drive.

Product Series	Procedures for Installing and Wiring Options on a Drive	Page
A1000	Procedure A	14
U1000	Procedure A	14
Z1000U	Procedure A	14
GA500	*1 *2	-
GA700	Procedure B	21
GA800	Procedure B	21
CR700	Procedure B	21
CH700	Procedure B	21

*1 To install the option on GA500 drives, use the option card mounting kit manual.

*2 Before you install the option on a YASKAWA AC Drive GA500, make sure that the option software version is PRG: 6202 or later.

■ Procedure A

This section shows the procedure to install and wire the option on a 1000-series drive.

Prepare the Drive for the Option

Correctly wire the drive as specified by the manual packaged with the drive. Make sure that the drive functions correctly. Refer to the following figure for an exploded view of the drive with the option and related components for reference in the installation procedure.

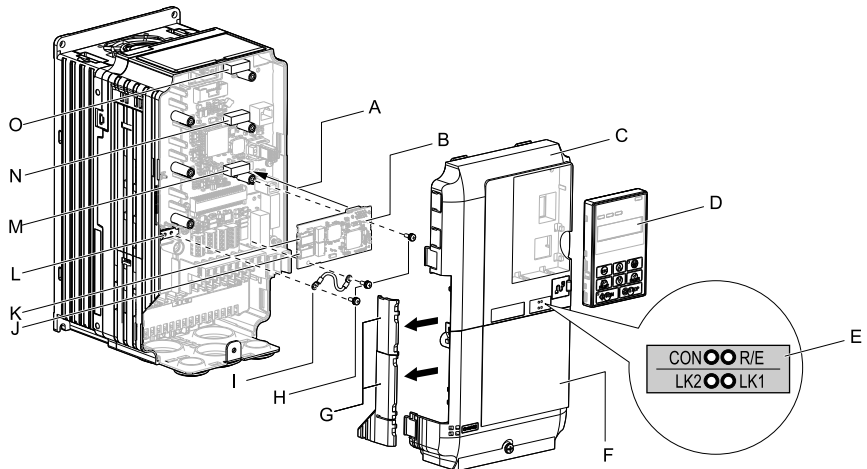

- | | |
|--|---|
| A - Insertion point for CN5 connector | I - Ground wire |
| B - Option | J - Option modular connector CN1 |
| C - Drive front cover | K - Option modular connector CN2 |
| D - Keypad | L - Drive grounding terminal (FE) |
| E - LED label | M - Connector CN5-A |
| F - Drive terminal cover | N - Connector CN5-B (Not available for communication option installation.) |
| G - Removable tabs for wire routing | O - Connector CN5-C (Not available for communication option installation.) |
| H - Included screws | |

Figure 5.1 Drive Components with Option

Install the Option

Remove the front covers of the drive before you install the option. Refer to the drive manual for information about how to remove the front covers. Different drive sizes have different cover removal procedures. You can only install this option into the CN5-A connector on the drive control board.

⚠ DANGER *Electrical Shock Hazard. Do not examine, connect, or disconnect wiring on an energized drive. Before servicing, disconnect all power to the equipment and wait for the time specified on the warning label at a minimum. The internal capacitor stays charged after the drive is de-energized. The charge indicator LED extinguishes when the DC bus voltage decreases below 50 Vdc. When all indicators are OFF, measure for dangerous voltages to make sure that the drive is safe. If you do work on the drive when it is energized, it will cause serious injury or death from electrical shock.*

1. Shut off power to the drive, wait the appropriate amount of time for voltage to dissipate, then remove the keypad (B) and front covers (A, C). Refer to the manual packaged with the drive for instructions on how to remove the cover.

NOTICE Observe correct electrostatic discharge (ESD) procedures when touching the option. Failure to obey can cause ESD damage to the option circuitry.

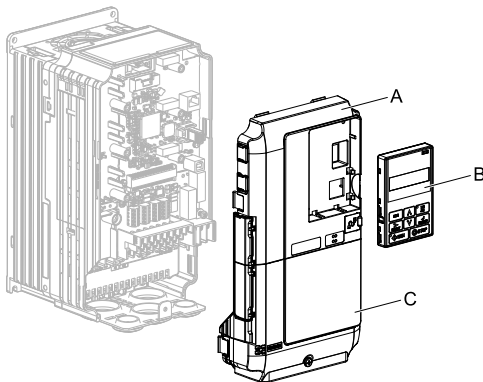

A - Drive front cover

C - Drive terminal cover

B - Keypad

Figure 5.2 Remove the Keypad, Front Cover, and Terminal Cover

- Put the LED label (B) in the appropriate position on the drive front cover (A).

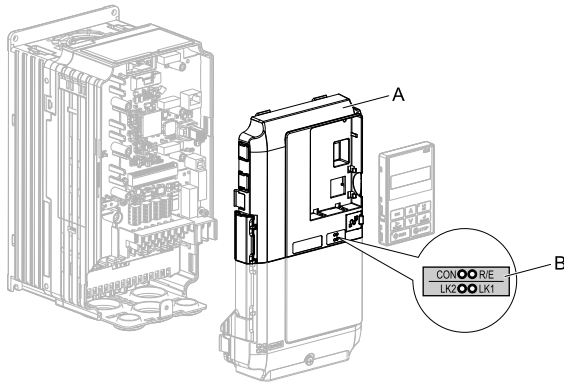

A - Drive front cover

B - LED label

Figure 5.3 Put the LED Label on the Drive Front Cover

3. Insert the option (A) into the CN5-A connector (C) on the drive and use the included screws (B) to put it in place. Tighten the screw to 0.5 to 0.6 N·m (4.4 to 5.3 in·lb).

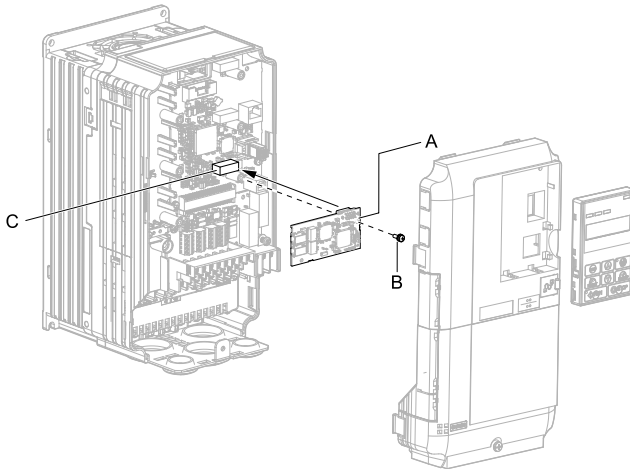

A - Option

C - Connector CN5-A

B - Included screws

Figure 5.4 Install the Option

4. Connect one end of the ground wire (C) to the ground terminal (B) using one of the remaining provided screws (D). Connect the other end of the ground wire (C) to the remaining ground terminal and installation hole on the option (A) using the last remaining provided screw (D).
 - Tighten both screws to 0.5 to 0.6 N·m (4.4 to 5.3 in·lb).

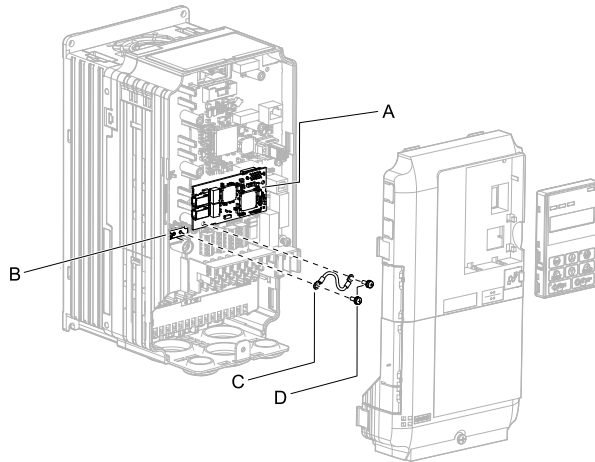

A - Option

B - Drive grounding terminal (FE)

C - Ground wire

D - Included screws

Figure 5.5 Connect the Ground Wire

Note:

The drive has only two ground terminal screw holes. When you connect three options, two options will share one ground terminal.

5. Select the proper MECHATROLINK-III dedicated communication cable according to [Table 5.1](#).
 - You can route the option wiring through openings on the front cover of some models. Remove the perforated tabs on the left side of the front cover as shown in [Figure 5.6-A](#) to create the necessary openings on these models.
 - Route the option wiring inside the enclosure as shown in [Figure 5.6-B](#). Take proper precautions so that the front covers will easily fit back onto the drive.

Refer to the Peripheral Devices & Options section of the drive instruction manual for more information.

Note:

Separate communication cables from main circuit wiring and other electrical lines to avoid potential sources of electrical interference.

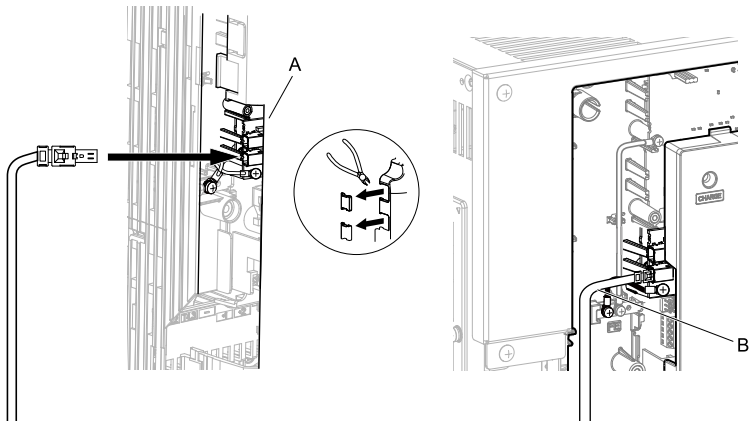

- A - Route wires through the openings provided on the left side of the front cover. *1** **B - Use the open space provided inside the drive to route option wiring.**

Figure 5.6 Wire Routing Examples

*1 If wiring is exposed outside the enclosure, the drive will not meet Enclosed wall-mounted type (IP20/UL Type 1) requirements.

6. Firmly connect the MECHATROLINK-III communication cable to option communication connector CN1 or CN2.
Install MECHATROLINK-III communications cables separately from main-circuit wiring and other electrical and power lines. Ensure the cable end is firmly connected (see [Figure 5.14](#)). Refer to [MECHATROLINK-III Communications Cables on page 26](#) for more information.
7. Reattach the drive front cover (A, C) and the keypad (B).
Refer to the manual packaged with the drive for instructions on how to reattach the cover.

NOTICE Do not pinch cables between the front covers and the drive. Failure to comply could cause erroneous operation.

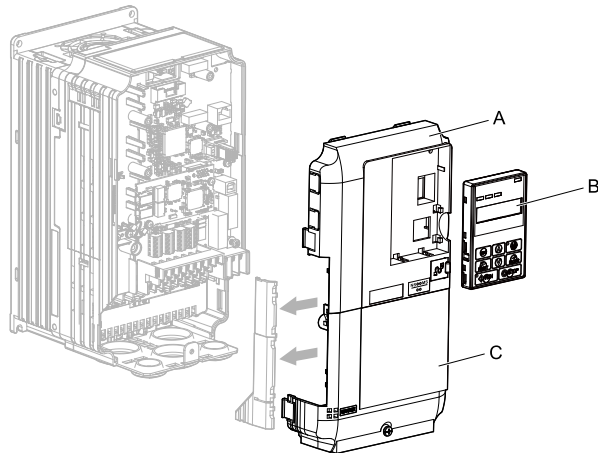

A - Drive front cover
B - Keypad

C - Drive terminal cover

Figure 5.7 Replace the Front Covers and Keypad

8. Set drive parameters in [Related Drive Parameters on page 29](#) for correct option performance.

■ Procedure B

This section shows the procedure to install and wire the option on a GA700, GA800, CR700, or CH700 drive.

Prepare the Drive for the Option

Before you install the option on a YASKAWA AC Drive GA700, GA800, CR700, or CH700, make sure that the option software version is PRG: 6202 or later.

Correctly wire the drive as specified by the manual packaged with the drive. Make sure that the drive functions correctly. Refer to the following figure for an exploded view of the drive with the option and related components for reference in the installation procedure.

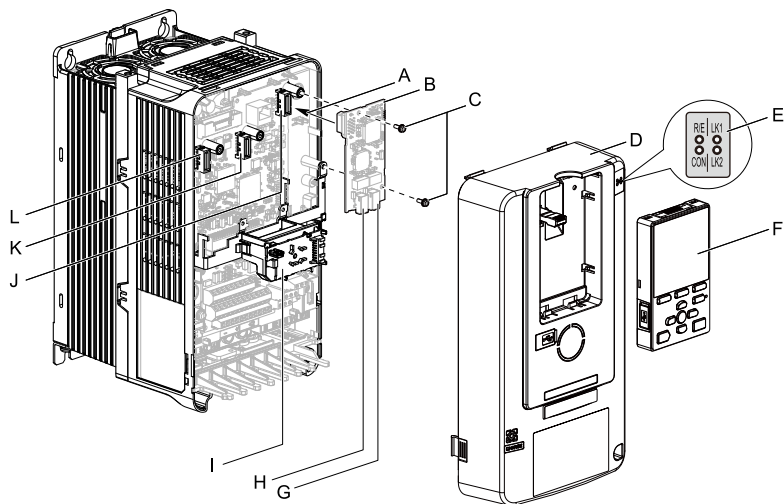

- | | |
|---------------------------------------|--|
| A - Insertion point for CN5 connector | G - Option modular connector CN1 |
| B - Option | H - Option modular connector CN2 |
| C - Included screws | I - LED Status Ring board |
| D - Drive front cover | J - Connector CN5-A |
| E - LED label | K - Connector CN5-B (Not available for communication option installation.) |
| F - Keypad | L - Connector CN5-C (Not available for communication option installation.) |

Figure 5.8 Drive Components with Option

Install the Option

Remove the front covers of the drive before you install the option. Refer to the drive manual for information about how to remove the front covers. Different drive sizes have different cover removal procedures. You can only install this option into the CN5-A connector on the drive control board.

⚠ DANGER *Electrical Shock Hazard. Do not examine, connect, or disconnect wiring on an energized drive. Before servicing, disconnect all power to the equipment and wait for the time specified on the warning label at a minimum. The internal capacitor stays charged after the drive is de-energized. The charge indicator LED extinguishes when the DC bus voltage decreases below 50 Vdc. When all indicators are OFF, measure for dangerous voltages to make sure that the drive is safe. If you do work on the drive when it is energized, it will cause serious injury or death from electrical shock.*

1. Put the LED label (A) in the correct position on the drive front cover (B).

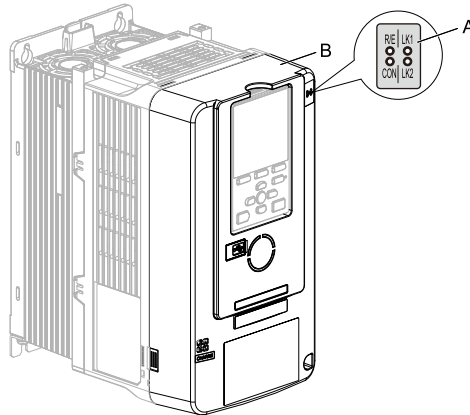

A - LED label

B - Drive front cover

Figure 5.9 Put the LED Label on the Drive Front Cover

2. Shut off power to the drive, wait the appropriate amount of time for voltage to dissipate, then remove the front cover (D).
Refer to the manual packaged with the drive for instructions on how to remove the cover.

NOTICE Observe correct electrostatic discharge (ESD) procedures when touching the option. Failure to obey can cause ESD damage to the option circuitry.

Note:

Remove the keypad, then move the keypad connector to the holder on the drive, then remove the front cover.

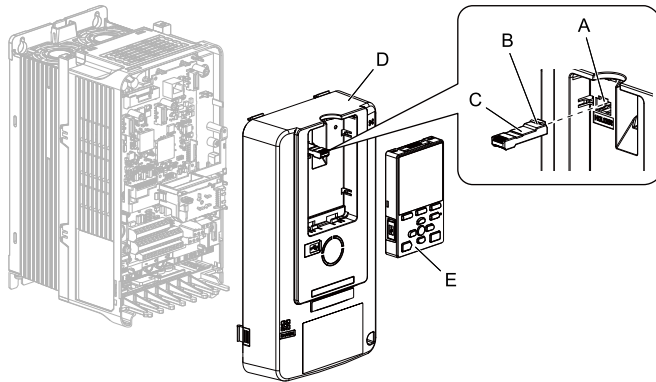

- A - Holder
- B - Keypad connector tab
- C - Keypad connector
- D - Drive front cover
- E - Keypad

Figure 5.10 Remove the Front Cover and Keypad

3. Carefully remove the LED Status Ring board (A) and put it in the temporary placement holes (B) on the right side of the drive.
Refer to the manual packaged with the drive for information about how to remove the LED Status Ring board.

NOTICE Do not remove the LED Status Ring board cable connector. If you disconnect the LED Status Ring board, it can cause incorrect operation and damage to the drive.

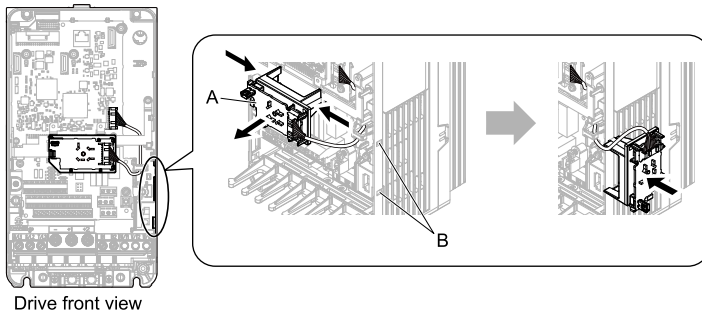

- A - LED Status Ring board
- B - Temporary placement holes

Figure 5.11 Remove the LED Status Ring Board

4. Insert the option (A) into the CN5-A connector (C) on the drive and use the included screws (B) to put it in place.
 - Tighten the screws to 0.5 to 0.6 N•m (4.4 to 5.3 in•lb).

Note:

1. A ground wire is not necessary. The option package ships with three screws and a ground wire for installation on other product series. Do not use the ground wire or the extra screw.
2. Only two screws are necessary to install the option on GA700, GA800, CR700, and CH700 drives.

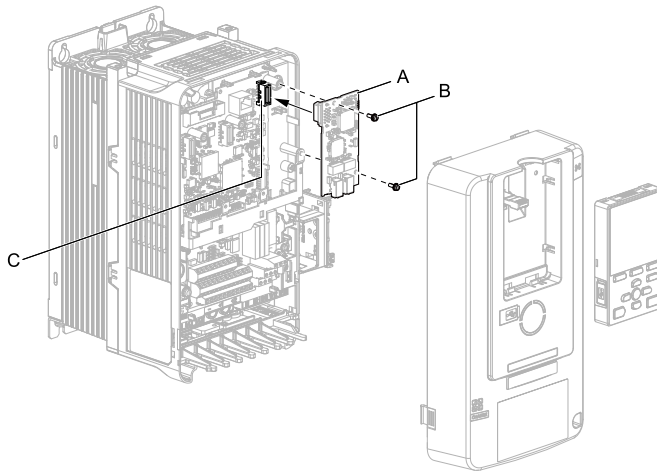
**A - Option****B - Included screws****C - Connector CN5-A****Figure 5.12 Insert the Option**

5. Select the proper MECHATROLINK-III dedicated communication cable according to [Table 5.1](#).

Firmly connect the MECHATROLINK-III communication cable to option communication connector CN1 or CN2. Isolate the communications cables from main circuit wiring and other electrical and power lines. Ensure the cable end is firmly connected (see [Figure 5.14](#)). Refer to [MECHATROLINK-III Communications Cables on page 26](#) for more information.

Note:

Maximum transmission distance is 100 m (328 ft). Minimum wiring distance between stations is 0.2 m (7.9 in).

6. Reattach the LED Status Ring board (E). Use the open space provided inside the LED Status Ring board to route option wiring. Reattach the drive front cover (C) and the keypad (D).
Refer to the manual packaged with the drive for information about how to reattach the LED Status Ring board.

NOTICE Do not pinch cables between the front cover or the LED Status Ring board and the drive. Failure to comply could cause erroneous operation.

Note:

- Replace the keypad connector then install the keypad.
- At that time, insert the keypad connector tab into the drive.

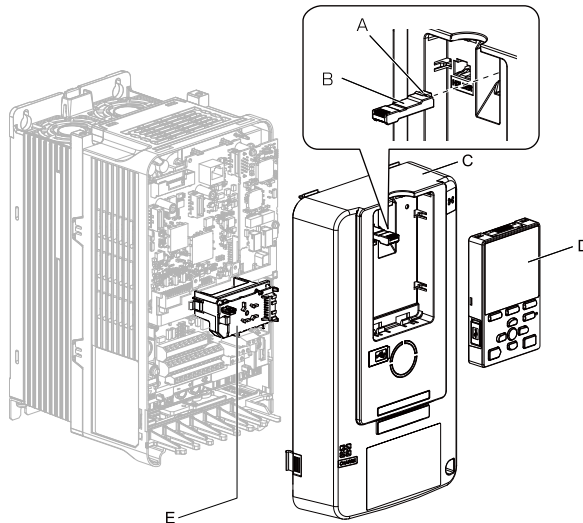

- A - Keypad connector tab
- B - Keypad connector
- C - Drive front cover

- D - Keypad
- E - LED Status Ring board

Figure 5.13 Replace the Front Cover and Keypad

7. Set drive parameters in [Related Drive Parameters on page 29](#) for correct option performance.

◆ MECHATROLINK-III Communications Cables

Connect the MECHATROLINK-III communication cable to option communication connector CN1 or CN2.

Use only a MECHATROLINK-III dedicated communication cable. Refer to [Table 5.1](#) for more information.

Note:

Maximum transmission distance is 100 m (328 ft). Minimum wiring distance between stations is 0.2 m (7.9 in).

■ **Option Connection Diagram**

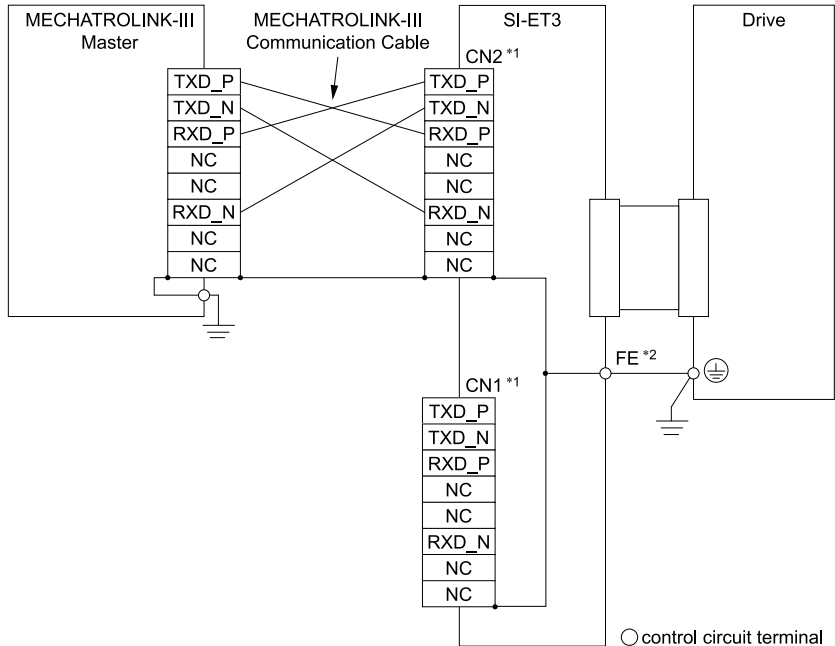

Figure 5.14 Option Connection Diagram

*1 Connect the MECHATROLINK-III cable to connector CN1 or CN2.

*2 Connect the provided ground wire for installations on 1000-series drives and GA500 drives.

The ground wire is not necessary for installation on GA700, GA800, CR700, or CH700 drives.

■ **Communication Cable Topology**

The dual communication cable ports on the option board act as a switch to allow for flexibility in cabling topology. Users may employ a traditional star network topology using a single communication cable port on the option. Users may also choose to employ a ring topology using both communication cable ports on the option and reduce the requirements of MECHATROLINK-III hub module ports.

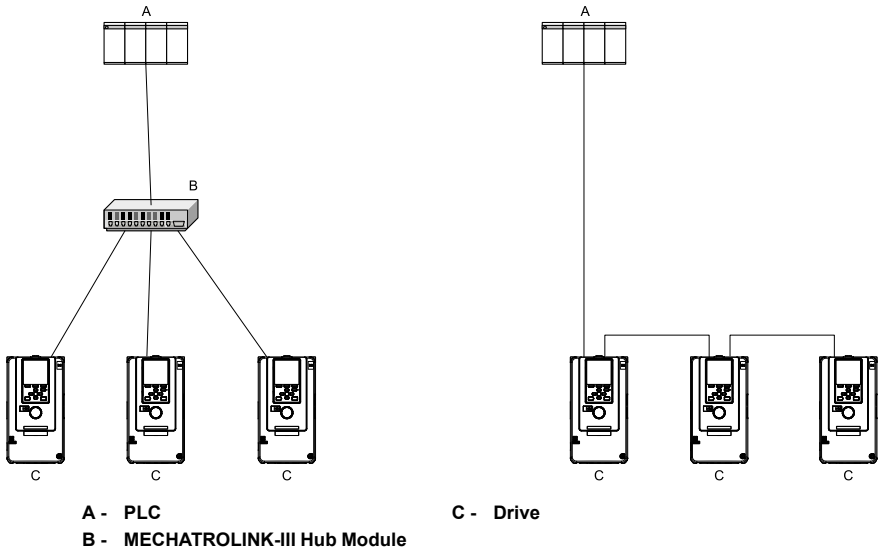
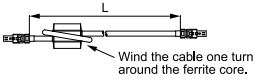
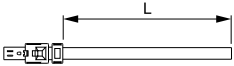

Figure 5.15 Topology Options

Table 5.1 MECHATROLINK-III Communications Cable

Connection Type	Cable Specification	Length (L)	Model
MECHATROLINK-III connection without ferrite core		0.2 m (7.9 in)	JEPMC-W6012-A2-E
		0.5 m (19.7 in)	JEPMC-W6012-A5-E
		1 m (39.4 in)	JEPMC-W6012-01-E
		2 m (78.7 in)	JEPMC-W6012-02-E
		3 m (118.1 in)	JEPMC-W6012-03-E
		4 m (157.5 in)	JEPMC-W6012-04-E
		5 m (196.9 in)	JEPMC-W6012-05-E
		10 m (393.7 in)	JEPMC-W6012-10-E
		20 m (787.4 in)	JEPMC-W6012-20-E
		30 m (1181.1 in)	JEPMC-W6012-30-E
50 m (1968.5 in)	JEPMC-W6012-50-E		

Connection Type	Cable Specification	Length (L)	Model
MECHATROLINK-III connection with ferrite core		10 m (393.7 in)	JEPMC-W6013-10-E
		20 m (787.4 in)	JEPMC-W6013-20-E
		30 m (1181.1 in)	JEPMC-W6013-30-E
		50 m (1968.5 in)	JEPMC-W6013-50-E
		75 m (2952.8 in)	JEPMC-W6013-75-E
		100 m (3937.0 in)	JEPMC-W6013-100-E
MECHATROLINK-III connection with loose wires at one end		0.5 m (19.7 in)	JEPMC-W6014-A5-E
		1 m (39.4 in)	JEPMC-W6014-01-E
		3 m (118.1 in)	JEPMC-W6014-03-E
		5 m (196.9 in)	JEPMC-W6014-05-E
		10 m (393.7 in)	JEPMC-W6014-10-E
		30 m (1181.1 in)	JEPMC-W6014-30-E
		50 m (1968.5 in)	JEPMC-W6014-50-E

6 Related Drive Parameters

The parameters in the following table set the drive for operation with the option. Confirm proper setting of all parameters in the following table before starting network communications.

Note:

Hex.: MEMOBUS addresses that you can use to change parameters over network communication are represented in hexadecimal numbers.

6 Related Drive Parameters

No. (Hex.)	Name	Description	Default (Range)
b1-01 (0180)	Frequency Reference Selection 1	<p>Selects the input method for frequency reference.</p> <p>0 : Keypad 1 : Digital Input 2 : Memobus/Modbus Communications 3 : Option 4 : Pulse Train Input</p> <p>Note:</p> <ul style="list-style-type: none"> Set <i>b1-02</i> = 3 to use the master device and serial communications to start and stop the drive. Set <i>b1-01</i> = 3 to use the master device to control the frequency reference of the drive. The default setting is different for different drives. Refer to the instruction manual of your specific drive for more information. 	1 (0 - 4)
b1-02 (0181)	Run Command Selection 1	<p>Selects the input method for the Run command.</p> <p>0 : Keypad 1 : Digital Input 2 : Memobus/Modbus Communications 3 : Option 7 : AUTO Command + Term Run 8 : AUTO Command + Serial Run 9 : AUTO Command + Option Run</p> <p>Note:</p> <ul style="list-style-type: none"> Set <i>b1-02</i> = 3 to start and stop the drive with the master device using serial communications. Set <i>b1-01</i> = 3 to use the master device to control the frequency reference of the drive. Settings 7 to 9 are available in HV600 software versions PRG: 1011 and later. 	1 (0 - 9)
F6-01 (03A2)	Communication Error Selection	<p>Selects drive response when the drive detects a <i>bUS</i> error during communications with the option.</p> <p>0 : Ramp to Stop 1 : Coast to Stop 2 : Fast Stop (Use C1-09) 3 : Alarm Only 4 : Alarm - Run at <i>d1-04</i> 5 : Alarm - Ramp Stop</p> <p>Note:</p> <ul style="list-style-type: none"> When you set this parameter to 3 [<i>Alarm only</i>] or 4 [<i>Alarm - run at d1-04</i>], the drive will continue operation after it detects a fault. Separately prepare safety protection equipment and systems, for example emergency switches. 	1 (0 - 5)

No. (Hex.)	Name	Description	Default (Range)
		<ul style="list-style-type: none"> Refer to the drive manual to know if settings 4 and 5 are available. This setting is available in A1000 software versions PRG: 1021 and later. The setting range for 1000-Series drives is different for different software versions. Refer to the Peripheral Devices & Options section of the drive instruction manual for more information. 	
F6-02 (03A3)	Comm External Fault [EF0] Detect	Selects the condition for external fault detection [EF0]. 0 : Always detected 1 : Detection during run only	0 (0, 1)
F6-03 (03A4)	Comm External Fault [EF0] Select	Selects drive response when the drive detects an external fault input [EF0] during option communications. 0 : Ramp to Stop 1 : Coast to Stop 2 : Fast Stop (Use C1-09) 3 : Alarm Only Note: When you set this parameter to 3, the drive will continue operation after it detects a fault. Separately prepare safety protection equipment and systems, for example fast stop switches.	1 (0 - 3)
F6-06 (03A7)	Torque Reference/Limit by Comm	When you enable this parameter, d5-01 determines whether the value is read as the Torque Limit value (d5-01 = 0) or the Torque Reference value (d5-01 = 1). 0 : Disabled 1 : Enabled Note: <ul style="list-style-type: none"> Control method availability of this parameter is different for different product series. <ul style="list-style-type: none"> –1000-Series Drives: Parameter is available in CLV, AOLV/PM, and CLV/PM. In AOLV/PM, this value is read as the Torque Limit. In AOLV/PM, this value is read as the Torque Limit. –GA500 Drive: Parameter is available in OLV, AOLV/PM, and EZOLV. This value is read as the Torque Limit. –GA700, GA800 Drives: Parameter is available in OLV, CLV, AOLV, AOLV/PM, CLV/PM, and EZOLV. In OLV and EZOLV, this value is read as the Torque Limit. –CR700, CH700 Drives: Parameter is available in OLV, CLV, and AOLV. This value is read as the Torque Limit. The setting specifies that network communications provide the torque reference or torque limit. If the PLC 	0 (0, 1)

6 Related Drive Parameters

No. (Hex.)	Name	Description	Default (Range)
		does not supply a torque reference or torque limit, the motor cannot rotate.	
F6-07 (03A8)	MultiStep Ref Priority Select	0 : MultiStep References Disabled 1 : MultiStep References Enabled Note: Default setting is 1 for GA500.	0 (0, 1)
F6-08 (036A)	Comm Parameter Reset @Initialize	Selects whether communication-related parameters <i>F6-xx</i> and <i>F7-xx</i> are set back to original default values when you use parameter <i>A1-03</i> [<i>Initialize Parameters</i>] to initialize the drive. 0 : No Reset - Parameters retained 1 : Reset - Back to factory default Note: The drive will not change this setting value when you set <i>F6-08</i> = 1 and use <i>A1-03</i> to initialize the drive.	0 (0, 1)
F6-20 (036B)	MECHATRO LINK Station Address	Sets the station number Note: • Cycle power for setting changes to take effect. • All station addresses must be unique. If set to 20 or 3F, a Station Address Error [<i>AEr</i>] will occur and the ERR light will turn on.	21 (Hex.) (03 - EF (Hex.))
F6-21 (036C)	MECHATRO LINK Frame Size	0 : 64-byte 1 : 32-byte Note: Cycle power for setting changes to take effect.	0 (0, 1)
F6-23 (036E)	MECHATRO LINK Monitor Select (E)	Set MEMOBUS/Modbus register to monitor SEL_MON of INV_CTL and INV_I/O. Note: • Cycle power for setting changes to take effect. • Set byte 21, SEL_MON1/2 of INV_CTL, or byte 38, SEL_MON 3/4 and byte 39, SEL_MON 5/6 of INV_I/O to 0E (Hex.) to enable the register set with <i>F6-23</i> . Bytes of the response data enable the register content set with <i>F6-23</i> . Refer to the manual packaged with the drive for more information about registers that you can set.	0 (Hex.) (0 - FFFF (Hex.))
F6-24 (036F)	MECHATRO LINK Monitor Select (F)	Set MEMOBUS/Modbus register to monitor SEL_MON of INV_CTL and INV_I/O. Note: • Cycle power for setting changes to take effect. • Set byte 21, SEL_MON1/2 of INV_CTL, or byte 38, SEL_MON 3/4 and byte 39, SEL_MON 5/6 of INV_I/O to 0F (Hex.) to enable the register set with <i>F6-24</i> . Bytes of the response data enable the register content set with <i>F6-24</i> . Refer to the manual packaged with the drive for more information about registers that you can set.	0 (Hex.) (0 - FFFF (Hex.))

No. (Hex.)	Name	Description	Default (Range)
F6-25 (03C9)	MECHATRO LINK Watchdog Error Sel	0 : Ramp to Stop 1 : Coast to Stop 2 : Fast Stop (Use C1-09) 3 : Alarm Only Note: When you set this parameter to 3 or 4, the drive will continue operation after it detects a fault. If you set this parameter to 3 or 4, make sure that you install an emergency stop switch.	1 (0 - 3)
F6-26 (03CA)	MECHATRO LINK <i>bUS</i> Errors Detected	When the option detects the <i>bUS</i> alarm for the number of times set in F6-26, it will detect <i>Option Communication Error [bUS]</i> .	2 (2 - 10)

7 Troubleshooting

◆ Drive-Side Error Codes

Drive-side error codes appear on the drive keypad. *Faults on page 33* lists causes of the errors and possible corrective actions. Refer to the drive Technical Manual for additional error codes that may appear on the drive keypad.

■ Faults

bUS [Option Communication Error], *E5 [MECHATROLINK Watchdog Timer Error]*, and *EF0 [Option Card External Fault from the option]* can appear as an alarm or as a fault.

When a fault occurs, the keypad ALM LED remains lit. When an alarm occurs, the ALM LED flashes.

If communication stops while the drive is running, use the following questions as a guide to help remedy the fault:

- Is the option properly installed?
- Is the communication line properly connected to the option? Is it loose?
- Is the controller program working? Has the controller/PLC CPU stopped?
- Did a momentary power loss interrupt communications?

Code	Name	Causes	Possible Solutions
bUS	Option Communication Error	The drive did not receive a signal from the controller.	<ul style="list-style-type: none"> • Check for wiring errors. • Correct the wiring.
		Faulty communications wiring	
		An existing short circuit or communications disconnection	Check disconnected cables and short circuits and repair as needed

Code	Name	Causes	Possible Solutions
		A data error occurred due to electric interference	<ul style="list-style-type: none"> Prevent noise in the control circuit, main circuit, and ground wiring. If you identify a magnetic contactor as a source of noise, install a surge absorber to the contactor coil. Use only recommended cables or other shielded line. Ground the shield on the controller side or the drive input power side. Separate all communication wiring from drive power lines. Install an EMC noise filter to the drive power supply input. Counteract noise in the master controller (PLC).
		Option is damaged	If there are no problems with the wiring and the error continues to occur, replace the option.
		Connection Time-out	<ul style="list-style-type: none"> The option Requested Packet Interval (RPI) timer timed out Make sure that RPI time is set properly
		Duplicate Station Address	Check if the option shares Station Address with at least one other node. Check the setting values of F6-20 [MECHATROLINK Station Address].
E5	MECHATROLINK Watchdog Timer Error	The drive detected a watchdog circuit exception while it received data from the controller.	<p>Check the MECHATROLINK cable connection. Check for wiring and how to counteract noise according to the following manuals by MECHATROLINK Members Association.</p> <ul style="list-style-type: none"> MECHATROLINK-III Installation Guide, MMATDEP018A
EF0	Option Card External Fault	The option received an external fault from the controller.	<ol style="list-style-type: none"> Find the device that caused the external fault and remove the cause. Clear the external fault input from the controller.
		A programming error occurred on the controller side.	Examine the operation of the controller program.
oFA00	Option Not Compatible with Port	The option connected to connector CN5-A is not compatible.	<p>Connect the option to the correct connector.</p> <ul style="list-style-type: none"> Use connector CN5-A when you connect the option. To use other options, refer to those option manuals.

Code	Name	Causes	Possible Solutions
oFA01	Option Card Fault (CN5-A)	The option connected to option port CN5-A was changed during run.	<ol style="list-style-type: none"> 1. De-energize the drive. 2. Connect the option to the correct option port.
oFA03, oFA04	Option Card Error (CN5-A)	A fault occurred in the option.	<ol style="list-style-type: none"> 1. De-energize the drive. 2. Make sure that the option is correctly connected to the connector. 3. If the problem continues, replace the option.
oFA30 to oFA43	Option Card Connection Error (CN5-A)	A fault occurred in the option.	<ol style="list-style-type: none"> 1. De-energize the drive. 2. Make sure that the option is correctly connected to the connector. 3. If the problem continues, replace the option.
oFb00	Option Not Compatible with Port	The option connected to connector CN5-B is not compatible.	<p>Connect the option to the correct connector.</p> <ul style="list-style-type: none"> • Use connector CN5-A when you connect the option. To use other options, refer to those option manuals.
oFb02	Option Fault	An option of the same type is already installed in option port CN5-A, CN5-B, or CN5-C.	Connect the option to the correct option port.
oFC00	Option Fault (CN5-B)	The option connected to connector CN5-C is not compatible.	<p>Connect the option to the correct connector.</p> <ul style="list-style-type: none"> • Use connector CN5-A when you connect the option. To use other options, refer to those option manuals.
oFC02	Option Fault	An option of the same type is already installed in option port CN5-A, CN5-B, or CN5-C.	Connect the option to the correct option port.

■ Minor Faults and Alarms

Code	Name	Causes	Possible Solutions
CALL	Serial communication transmission error	The communications cable wiring is incorrect.	<ul style="list-style-type: none"> • Check for wiring errors. • Correct the wiring.
		An existing short circuit or communications disconnection	Check disconnected cables and short circuits and repair as needed.
		Programming error on the master side	Check communications at start-up and correct programming errors.

Code	Name	Causes	Possible Solutions
		Communication circuitry is damaged.	<ul style="list-style-type: none"> Perform a self-diagnostics check If the problem continues, replace either the control board or the entire drive. For instructions on replacing the control board, contact Yaskawa or a Yaskawa representative.
CyC	MECHATROLINK Communications Cycle Setting Error	The upper controller is using a communication cycle beyond the allowable setting range for the MECHATROLINK option.	Set the communication cycle for the upper controller within the allowable setting range for the MECHATROLINK option.
CyPo	Cycle Power to Active Parameters	Comm. Option Parameter Not Upgraded	Re-energize the drive to update the communication option parameters. Note: If the option software version is not compatible or if you install an incorrect option to the drive, it will trigger an alarm.

◆ Option Compatibility

Users may connect up to 3 options simultaneously depending on the type of option.

Note:

You can only connect one option to the GA500. Connect the option to the CN5 connector.

Table 7.1 Option Compatibility

Option	Connector	Number of Options Possible
PG-B3, PG-X3	CN5-B, C	2 ^{*1}
PG-RT3 ^{*2} ^{*3} , PG-F3 ^{*2} ^{*3}	CN5-C	1
DO-A3, AO-A3	CN5-A, B, C	1
SI-C3, SI-N3, SI-P3, SI-S3, SI-T3, SI-ET3, SI-ES3, SI-B3, SI-M3, SI-W3 ^{*3} , SI-EM3 ^{*3} , SI-EN3 ^{*3} , SI-EP3, AI-A3 ^{*4} , DI-A3 ^{*4}	CN5-A	1

*1 To connect two PG options, use the CN5-C and CN5-B connectors. To connect only one PG option, use the CN5-C connector.

*2 If you use the motor switching function, you cannot use this option.

*3 Not available with 1000-Series drive models with a capacities between 450 and 630 kW.

*4 When you use the input status of AI-A3 and DI-A3 as a monitor, you can connect AI-A3 and DI-A3 to CN5-A, CN5-B, or CN5-C.

8 European Standards



Figure 8.1 CE Mark

The CE mark indicates compliance with European safety and environmental regulations. European standards include the Machinery Directive for machine manufacturers, the Low Voltage Directive for electronics manufacturers, and the EMC guidelines for controlling noise.

It is required for engaging in business and commerce in Europe.

This option displays the CE mark based on the EMC guidelines.

EMC Guidelines: 2014/30/EU

Drives used in combination with this option and devices used in combination with the drive must also be CE certified and display the CE mark.

When using drives displaying the CE mark in combination with other devices, it is ultimately the responsibility of the user to ensure compliance with CE standards. Verify that conditions meet European standards after setting up the device.

◆ EMC Guidelines Compliance

This option is tested according to European standards EN 61800-3:2004/A1:2012 and complies with EMC guidelines. The CE marking is declared based on the harmonized standards.

■ EMC Guidelines Installation Conditions

Verify the following installation conditions to ensure that other devices and machinery used in combination with this option and drives also comply with EMC guidelines:

1. Use dedicated shield cable for the option and external device (encoder, I/O device, master), or run the wiring through a metal conduit.

- Keep wiring as short as possible and ground the largest possible surface area of the shield to the metal panel as specified by Figure 8.2 and Figure 8.3.

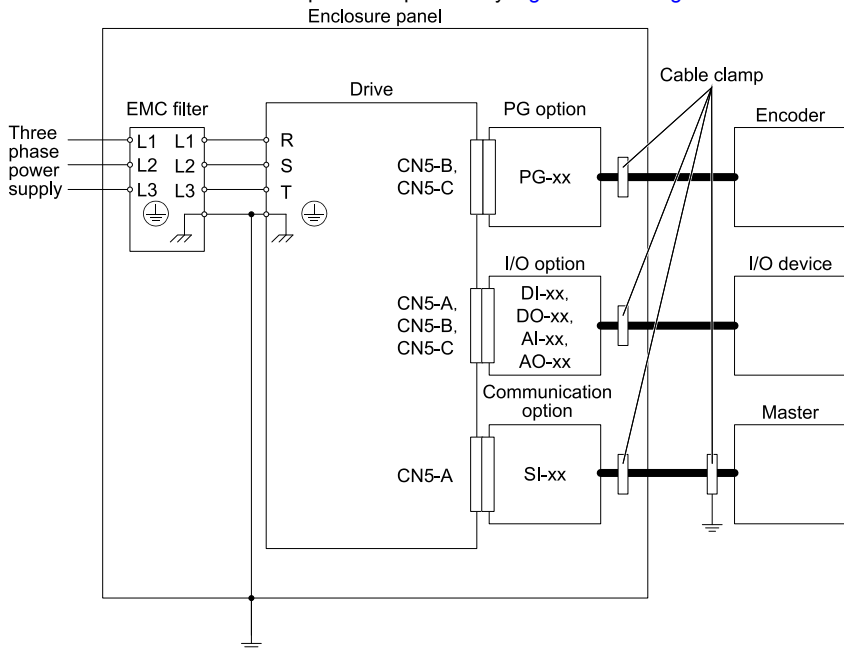

Figure 8.2 Option Installation for CE Compliance: 1000-Series, GA700, GA800, CR700, CH700

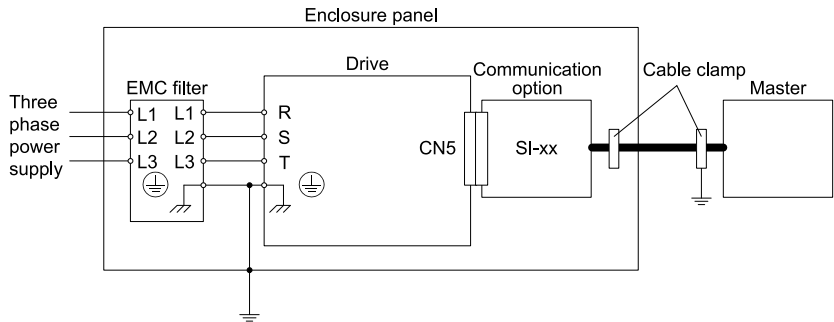
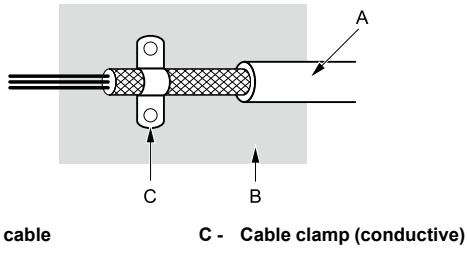

Figure 8.3 Option Installation for CE Compliance with GA500

3. Ground the largest possible surface area of the shield to the metal panel. Use cable clamps if possible.



A - Braided shield cable
B - Metal panel

C - Cable clamp (conductive)

Figure 8.4 Ground Area

9 Specifications

◆ Specifications

Table 9.1 Option Specifications

Item	Specification
Model	SI-ET3
Access mode	MECHATROLINK-III
Communication speed	100 Mbps
Minimum transmission cycle	250 μ s
Maximum transmission cycle	8 ms

Item	Specification
Transmission cycle granularity	03 (Hex.)
Minimum wiring distance between stations	0.2 m (7.9 in)
Maximum wiring distance between stations	100 m (328 ft)
Data length	32-byte data transmission or 64-byte data transmission
Event driven communication	Valid
Profile	Compliant with standard inverter profile
Maximum number of stations	62 *1
Ambient temperature	-10°C to +50°C (14°F to 122°F)
Humidity	Up to 95% RH (no condensation)
Storage temperature	-20°C - +60°C (-4°F to 140°F) allowed for short-term transport of the product
Area of use	Indoors in an area that does not have: <ul style="list-style-type: none"> • Oil mist, corrosive gas, flammable gas, or dust • Radioactive materials or flammable materials, including wood • Harmful gas or fluids • Salt • Direct sunlight • Falling foreign objects
Altitude	Up to 1000 m (3280 ft)

*1 The maximum number of connectable stations changes depending on the types and settings of the host controller, baud rate, and communications cycle. Refer to the host controller manual for more information.

10 Disposal

◆ Disposal Instructions

Correctly dispose of the product and packing material as specified by applicable regional, local, and municipal laws and regulations.

◆ **WEEE Directive**

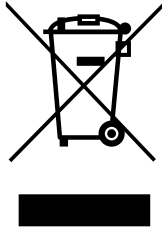

The wheeled bin symbol on this product, its manual, or its packaging identifies that you must recycle it at the end of its product life.

You must discard the product at an applicable collection point for electrical and electronic equipment (EEE). Do not discard the product with usual waste.

Revision History

Date of Publication	Revision Number	Section	Revised Content
February 2026	2	Back cover	Revision: Address
April 2024	1	Back cover	Revision: Address
October 2019	-	-	First Edition This manual is created base on TOBP C730600 88E<5>-0.

YASKAWA AC Drive Option MECHATROLINK-III Installation Manual

DRIVE CENTER (INVERTER PLANT)

2-13-1, Nishimiyaichi, Yukuhashi, Fukuoka,
824-8511, Japan
Phone: +81-930-25-2548 Fax: +81-930-25-3431
www.yaskawa.co.jp

YASKAWA ELECTRIC CORPORATION

New Pier Takeshiba South Tower, 1-16-1, Kaigan,
Minatoku, Tokyo, 105-6891, Japan
Phone: +81-3-5402-4502 Fax: +81-3-5402-4580
www.yaskawa.co.jp

YASKAWA AMERICA, INC.

2121, Norman Drive South, Waukegan, IL 60085, U.S.A.
Phone: +1-800-YASKAWA (927-5292) or +1-847-887-7000
Fax: +1-847-887-7310
www.yaskawa.com

YASKAWA ELÉTRICO DO BRASIL LTDA.

777, Avenida Piraporinha, Diadema, São Paulo,
09950-000, Brasil
Phone: +55-11-3585-1100 Fax: +55-11-3585-1187
www.yaskawa.com.br

YASKAWA EUROPE GmbH

Philipp-Reis-Str. 6, 65795 Hattersheim am Main, Germany
Phone: +49-6196-569-300
www.yaskawa.eu.com
E-mail: support@yaskawa.eu

YASKAWA ELECTRIC KOREA CORPORATION

6F, 112, LS-ro, Dongan-gu, Anyang-si, Gyeonggi-do, Korea
Phone: +82-31-8015-4224 Fax: +82-31-8015-5034
www.yaskawa.co.kr

YASKAWA ASIA PACIFIC PTE. LTD.

30A, Kallang Place, #06-01, 339213, Singapore
Phone: +65-6282-3003 Fax: +65-6289-3003
www.yaskawa.com.sg

YASKAWA ELECTRIC (THAILAND) CO., LTD.

59, 1F-5F, Flourish Building, Soi Ratchadapisek 18,
Ratchadapisek Road, Huaykwang, Bangkok, 10310,
Thailand
Phone: +66-2-017-0099 Fax: +66-2-017-0799
www.yaskawa.co.th

YASKAWA ELECTRIC (CHINA) CO., LTD.

22F, Link Square 1, No.222, Hubin Road, Shanghai,
200021, China
Phone: +86-21-5385-2200 Fax: +86-21-5385-3299
www.yaskawa.com.cn

YASKAWA ELECTRIC (CHINA) CO., LTD.

BEIJING OFFICE
Room 1011, Tower W3 Oriental Plaza, No. 1,
East Chang An Avenue,
Dong Cheng District, Beijing, 100738, China
Phone: +86-10-8518-4086 Fax: +86-10-8518-4082

YASKAWA ELECTRIC TAIWAN CORPORATION

12F, No. 207, Section 3, Beishin Road, Shindian District,
New Taipei City 23143, Taiwan
Phone: +886-2-8913-1333
Fax: +886-2-8913-1513 or +886-2-8913-1519
www.yaskawa.com.tw

YASKAWA INDIA PRIVATE LIMITED

#17/A, Electronics City, Hosur Road, Bengaluru,
560 100 (Karnataka), India
Phone: +91-80-4244-1900 Fax: +91-80-4244-1901
www.yaskawaindia.in

YASKAWA

YASKAWA ELECTRIC CORPORATION

In the event that the end user of this product is to be the military and said product is to be employed in any weapons systems or the manufacture thereof, the export will fall under the relevant regulations as stipulated in the Foreign Exchange and Foreign Trade Act. Therefore, be sure to follow all procedures and submit all relevant documentation according to any and all rules, regulations and laws that may apply.

Specifications are subject to change without notice for ongoing product modifications and improvements.

© 2019 YASKAWA ELECTRIC CORPORATION



TOEPC73060088

MANUAL NO. TOEP C730600 88A <2>-J0
Published in Japan February 2026
25-9-27
Original Instructions