

YASKAWA AC Drive Option EtherNet/IP Installation Manual

Model SI-EN3

To correctly use the product, read this manual thoroughly and keep it for easy reference, inspection, and maintenance. Make sure that the end user receives this manual.

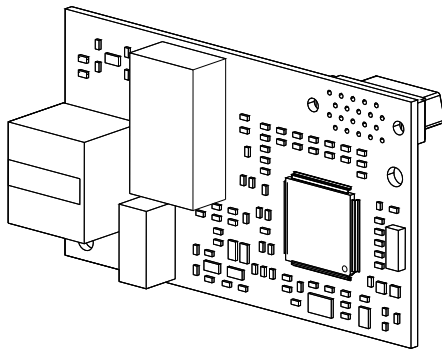

This Page Intentionally Blank

Table of Contents

1.	Preface and Safety	6
	Applicable Documentation	7
	Glossary	7
	Registered Trademarks	8
	Supplemental Safety Information	8
	Section Safety	8
2.	Overview	9
	Compatible Products	9
	Install the Option on a GA500 Drive	11
3.	Receiving	12
	Option Package Contents	12
	Installation Tools	13
4.	Option Components	14
	Option	14
	Communication Modular Connector CN1 Port 1/Port 2	14
	Option LED States	15
	Power-Up Diagnostics	17
5.	Installation Procedure	17
	Section Safety	17
	Procedures to Install and Wire Options on a Drive	18
	Procedure A	19
	Procedure B	25
	Procedure C	31
	Procedure D	36
	IGMP Snooping	44

Communication Cable Specifications	44
Option Connection Diagram	45
EDS Files	45
6. Related Drive Parameters	45
7. EtherNet/IP Configuring Messaging	55
Drive Polled Configuration.	55
Converter Polled Configuration.	56
8. Output Assemblies (Drive Consumes)	58
EtherNet/IP Basic Speed Control Output - 20 (0x14)	58
EtherNet/IP Extended Speed Control Output - 21 (0x15)	58
9. Input Assemblies (Drive Produces)	59
EtherNet/IP Basic Speed Control Input - 70 (0x46)	60
EtherNet/IP Extended Speed Control Input - 71 (0x47)	60
10. Output Assemblies (Converter Consumes)	62
EtherNet/IP Basic Speed Control Output - 20 (0x14)	62
EtherNet/IP Extended Speed Control Output - 21 (0x15)	63
11. Input Assemblies (Converter Produces)	64
EtherNet/IP Basic Speed Control Input - 70 (0x46)	64
EtherNet/IP Extended Speed Control Input - 71 (0x47)	65
12. Web Interface	66
Home Page.	66
EtherNet/IP Page	67
Network Page.	69
13. Troubleshooting	71
Drive-Side Error Codes	71
Faults	71
Minor Faults and Alarms	73
Explicit Message Communications Errors	73
Option Error Codes	74
Option Fault Monitors <i>U6-98</i> and <i>U6-99</i>	74
Option Compatibility.	75
14. Option Installation.	76

15. Specifications	78
Specifications	78
16. Disposal	79
Disposal Instructions	79
WEEE Directive	79
Revision History	80

1 Preface and Safety

YASKAWA Electric supplies component parts for use in a wide variety of industrial applications. The selection and application of YASKAWA products remain the responsibility of the equipment designer or end user.

YASKAWA accepts no responsibility for the way its products are incorporated into the final system design. Under no circumstances should any YASKAWA product be incorporated into any product or design as the exclusive or sole safety control. Without exception, all controls should be designed to detect faults dynamically and fail safely under all circumstances. All products designed to incorporate a component part manufactured by YASKAWA must be supplied to the end user with appropriate warnings and instructions as to the safe use and operation of that part. Any warnings provided by YASKAWA must be promptly provided to the end user. YASKAWA offers an express warranty only as to the quality of its products in conforming to standards and specifications published in the manual. **NO OTHER WARRANTY, EXPRESS OR IMPLIED, IS OFFERED.** YASKAWA assumes no liability for any personal injury, property damage, losses, or claims arising from misapplication of its products.

◆ Applicable Documentation

Document	Description
YASKAWA AC Drive Option EtherNet/IP Installation Manual (This book)	Read this manual first. The manual provides information about wiring, settings, functions, and troubleshooting. The manual is packaged together with the product.
YASKAWA AC Drive Option EtherNet/IP Technical Manual Manual No.: SIEP C730600 92	The technical manual contains detailed information about the option. Access the following sites to obtain the technical manual: U.S.: http://www.yaskawa.com Europe: http://www.yaskawa.eu.com Japan: http://www.e-mechatronics.com Other areas: Check the back cover of these manuals. For questions, contact Yaskawa or a Yaskawa representative.
YASKAWA AC Drive Manuals	Refer to the drive manual to connect with the option. Drive manuals contain basic installation and wiring information in addition to detailed parameter setting, fault diagnostic, and maintenance information. The manuals also include important information about parameter settings and tuning the drive. The Quick Start Guides are packaged with the drive. The most recent versions of these manuals are available for download on our documentation websites: U.S.: http://www.yaskawa.com Europe: http://www.yaskawa.eu.com Japan: http://www.e-mechatronics.com Other areas: Check the back cover of these manuals. For questions, contact Yaskawa or a Yaskawa representative.

◆ Glossary

Term	Definition
Option	YASKAWA AC Drive Option SI-EN3 EtherNet/IP
Keypad	<ul style="list-style-type: none"> • HOA Operator • LCD Operator • LED Operator • HOA Keypad • LCD Keypad • LED Keypad
Hex. (Example: 900 (Hex.))	Identifies a unit for hexadecimal number format.

◆ Registered Trademarks

- EtherNet/IP is a registered trademark of Open DeviceNet Vendor Association, Inc. (ODVA).
 - Trademarks are the property of their respective owners.
-

◆ Supplemental Safety Information

Read and understand this manual before installing, operating, or servicing this option. The option must be installed according to this manual and local codes.

The following conventions are used to indicate safety messages in this manual. Failure to heed these messages could result in serious or possibly even fatal injury or damage to the products or to related equipment and systems.

▲ DANGER *This signal word identifies a hazard that will cause serious injury or death if you do not prevent it.*

▲ WARNING *This signal word identifies a hazard that can cause death or serious injuries if you do not prevent it.*

▲ CAUTION *This signal word identifies a hazardous situation, which, if not avoided, can cause minor or moderate injury.*

NOTICE *This signal word identifies a property damage message that is not related to personal injury.*

■ Section Safety

General Precautions
<ul style="list-style-type: none">• The diagrams in this section may include options and drives without covers or safety shields to illustrate details. Be sure to reinstall covers or shields before operating any devices. The option should be used according to the instructions described in this manual.• The diagrams in this manual are provided as examples only and may not pertain to all products covered by this manual.• The products and specifications described in this manual or the content and presentation of the manual may be changed without notice to improve the product and/or the manual.• Contact Yaskawa or a Yaskawa representative and provide the manual number shown on the front cover to order new copies of the manual.

▲ DANGER *Do not ignore the safety messages in this manual. If you ignore the safety messages in this manual, it will cause serious injury or death. The manufacturer is not responsible for injuries or damage to equipment.*

▲ WARNING *Electrical Shock Hazard. Do not modify the drive or option circuitry. Failure to obey can cause serious injury or death, or cause damage to the drive or option and will void warranty. Yaskawa is not responsible for modifications of the product made by the user.*

NOTICE *Damage to Equipment. Do not use steam or other disinfectants to fumigate wood for packaging the drive. Use alternative methods, for example heat treatment, before you package the components. Gas from wood packaging fumigated with halogen disinfectants, for example fluorine, chlorine, bromine, iodine or DOP gas (phthalic acid ester), can cause damage to the drive.*

2 Overview

The option provides a communications connection between the drive and an ODVA EtherNet/IP network. The option connects the drive to an EtherNet/IP network and facilitates the exchange of data.

EtherNet/IP is a communications link to connect industrial devices (such as smart motor controllers, operator interfaces, and variable frequency drives) as well as control devices (such as programmable controllers and computers) to a network. The option is a simple, networking solution. EtherNet/IP decreases the cost and time to wire and install factory automation devices, and it gives the option to interchange like components from other vendors.

EtherNet/IP is an open device network standard.

Install the option on a drive to perform the following functions from an EtherNet/IP master device:

- Operate the drive
- Monitor the drive operation status
- Change drive parameter settings



Figure 2.1 EtherNet/IP Certification Mark

◆ Compatible Products

You can use the option with these products:

Table 2.1 Compatible Products

Drive	Model	Software Version ^{*1}
A1000	CIMR-Ax2Axxxx	≥ 1020
	CIMR-Ax4A0002 - 4A0675	
	CIMR-Ax4A0930, 4A1200	≥ 3015
	CIMR-Ax5Axxxx	≥ 5040 ≥ 1020
D1000	CIMR-Dx2A0005 - 4A0370	≥ 2600
	CIMR-Dx4A0630	≥ 3014
R1000	CIMR-Rx2A03P5 - 4A0300	≥ 2102

Drive	Model	Software Version ^{*/}
U1000	CIMR-UxxAxxxx	≥ 1015
	CIMR-UxxExxxx	
	CIMR-UxxPxxxx	
	CIMR-UxxWxxxx	
U1000L	CIMR-UxxLxxxx	≥ 6210
	CIMR-UxxFxxxx	
	CIMR-UxxRxxxx	
	CIMR-UxxSxxxx	
Z1000	CIMR-ZxxAxxxx	≥ 1014
Z1000U	CIMR-ZxxUxxxx	≥ 6113
	CIMR-ZxxExxxx	
	CIMR-ZxxPxxxx	
	CIMR-ZxxWxxxx	
GA500 ^{*2}	CIPR-GA50xxxxx	≥ 1010
GA700 ^{*2}	CIPR-GA70xxxxx	≥ 1010
GA800 ^{*2}	CIPR-GA80xxxxx	≥ 9010
CR700 ^{*2}	CIPR-CR70xxxxx	≥ 1012
CH700 ^{*2}	CIPR-CH70xxxxx	≥ 1012
HV600 ^{*2}	CIPR-HV60xxxxx	≥ 1011
FP605 ^{*3}	CIPR-FP65xxxxx	≥ 1010

*1 Refer to “PRG” on the drive nameplate for the software version number.

*2 Before you install the option on a GA500, GA700, GA800, CR700, CH700, or HV600 drive, make sure that the option software version is PRG: 4103 or later.

*3 Before you install the option on an FP605 drive, make sure that the option software version is PRG: 4106 or later.

Note:

- Refer to the option package labeling in the field designated “PRG (four digit number)” to identify the option software version.
- For Yaskawa customers in the North or South America regions:
If your product is not listed in [Table 2.1](#), refer to the web page below to confirm this manual is correct for your product. The web page provides a list of option manuals by product, and a direct link to download a PDF of the manual.

Scan QR code Or refer to:

<http://www.yaskawa.com/optionlookup>



◆ Install the Option on a GA500 Drive

An option card mounting kit is necessary to install the option on a GA500 drive. The option card mounting kit model is: JOHB-GA50. This kit is sold separately.

Refer to the option card mounting kit manual for more information about installation.

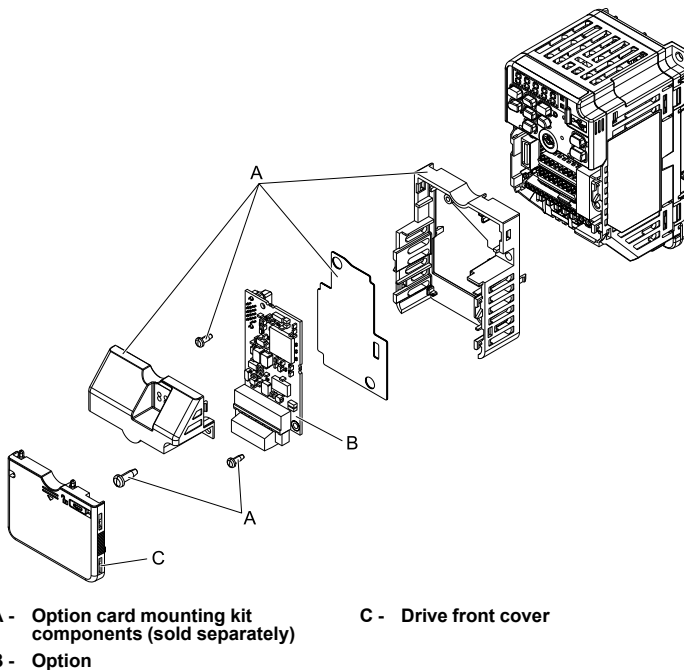

Figure 2.2 Option Card Mounting Kit (JOHB-GA50)

3 Receiving

After receiving the option package:

- Make sure that there is no damage to the option and there are no missing parts.
The Yaskawa warranty does not include damage from shipping. Immediately contact the shipping company if the option or other parts are damaged.



NOTICE



Damage to Equipment. Do not use damaged parts to connect the drive and the option. Failure to comply could damage the drive and option.

- Make sure that the model number on the option nameplate and the model number on the purchase order are the same. Refer to [Figure 4.1](#) for more information.
- Contact the distributor where you purchased the option or contact Yaskawa or a Yaskawa representative about any problems with the option.

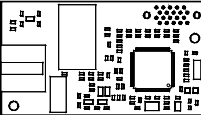
◆ Option Package Contents

Table 3.1 Contents of Package

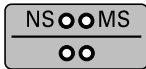
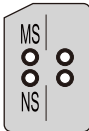
Option Contents		Quantity
Option		1
Ground wire <i>*1</i>		1
Screws (M3)		3 <i>*2</i>

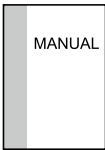
Option Contents		Quantity	
LED label	1000-Series, Z1000U		1
	GA500, GA700, GA800, CR700, and CH700		1
	Z1000, HV600, and FP605 ^{*3}		1 ^{*4}
Manuals		1	

*1 GA500, GA700, GA800, CR700, and CH700 drives do not use the ground wire.

*2 GA700, GA800, CR700, CH700, HV600, and FP605 drives use two screws only.

*3 LED label has transparent background and white letters. Please make sure that you use the correct label for Z1000, HV600, or FP605.

*4 Options purchased in Japan do not include LED labels for Z1000, HV600, or FP605.

◆ Installation Tools

You can use these tools to install the option to the drive:

- A Phillips screwdriver or slotted screwdriver (blade depth: 0.4 mm (0.02 in), width: 2.5 mm (0.1 in)) ^{*1}.
- A pair of diagonal cutting pliers.
- A small file or medium-grit sandpaper.

*1 Phillips screw sizes are different for different drive capacities. Prepare different screwdrivers for different screw sizes.

4 Option Components

◆ Option

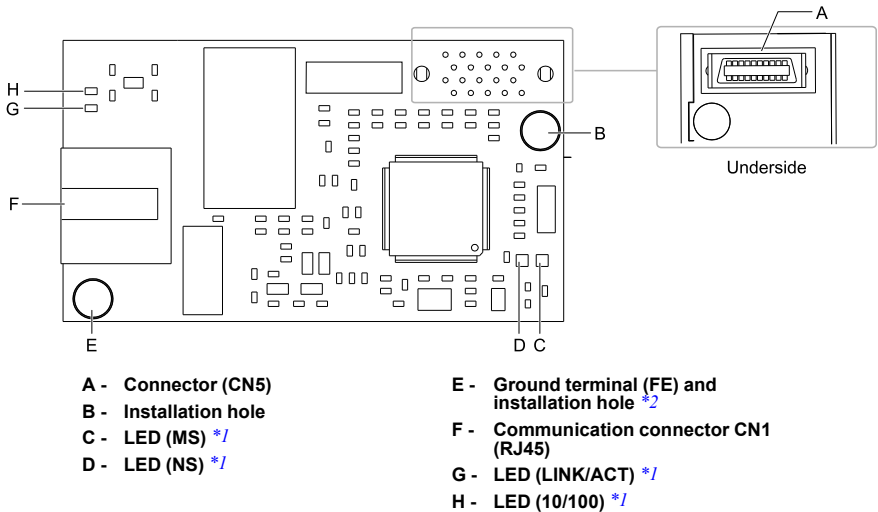

Figure 4.1 Option

*1 Refer to [Option LED States on page 15](#) for more information about the LEDs.

*2 Connect the included ground wire during installation. The ground wire is not necessary for installation on GA700, GA800, CR700, and CH700 drives. For GA500, connect the included ground wire to the separately sold communication option case (model: JOHB-GA50).

◆ Communication Modular Connector CN1 Port 1/Port 2

The communication modular connector CN1 on the option is a modular dual RJ45 female connector designated port 1 and port 2. Port 1 and port 2 are the connection points for a customer-supplied male EtherNet/IP network communication cable.

Table 4.1 Male 8-way Ethernet Modular Connector (Customer-Supplied)

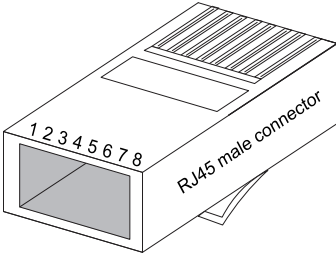
Male EtherNet 8-Way Modular Connector	Pin	Description
	1 (Pair 2)	Transmit data (TXD) +
	2 (Pair 2)	Transmit data (TXD) -
	3 (Pair 3)	Receive data (RXD) +
	4 (Pair 1)	Not used ^{*1}
	5 (Pair 1)	Not used ^{*1}
	6 (Pair 3)	Receive data (RXD) -
	7 (Pair 4)	Not used ^{*1}
	8 (Pair 4)	Not used ^{*1}

*1 Not used for 10 Mbps and 100 Mbps networks.

◆ Option LED States

The option has four LEDs:

- Bi-color Status LEDs:
 - Module status (MS) red/green
 - Network status (NS) red/green
- Ethernet LEDs:
 - Network speed-10/100 green
 - Link status and network activity-Link/Act green

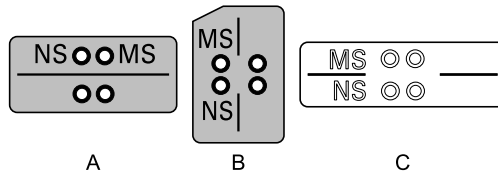

A - 1000-Series, Z1000U

**B - GA500, GA700, GA800, CR700,
and CH700**

C - Z1000, HV600, and FP605 ^{*1}

Figure 4.2 Option LED Labels

*1 LED label has transparent background and white letters. Please make sure that you use the correct label for Z1000, HV600, or FP605.

Wait 2 seconds minimum for the power-up diagnostic process to complete before you verify the LED states. The [Table 4.2](#) shows the operating status of the option LEDs after the power-up diagnostic LED sequence is complete. Refer to [Table 4.3](#) for more information about the LEDs.

Table 4.2 Option LED States

LED Name	Indication		Operating State	Description
	Color	Display		
MS	-	OFF	Power supply off	There is no power to the drive.
	Green	ON	Option operating	The option is operating normally.
	Green	Flashing	Option initializing	The option is configuring an IP address.
	Red	ON	Fatal error occurred	The option detected a fatal (unrecoverable) error.
	Red	Flashing	Non-fatal error occurred	The option detected a non-fatal (recoverable) error.
	Red/ Green	Flashing	Option self-test	The option is in self-test mode.
NS	-	OFF	Power supply OFF or Offline	-
	Green	ON	Online communications established	The option is online and has established connections.
	Green	Flashing	Online communications not established	The option is online without an established connection.
	Red	ON	Communications error (fatal)	The option detected a duplicate IP address.
	Red	Flashing	Communications time-out (non-fatal)	A communications time-out occurred.
	Red/ Green	Flashing	Option self-test	The option is in self-test mode.
10/100 *1	Green	OFF	10 Mbps is established	-
	Green	ON	100 Mbps is established	
LINK/ ACT *1	Green	OFF	Link is not established	
	Green	ON	Link is established	
	Green	Flashing	Link is established and there is network activity	

*1 To verify LED states, you must remove the drive front cover. Do not touch the drive main circuit terminal or circuit boards when you remove the drive front cover.

■ Power-Up Diagnostics

An LED test is performed each time the drive is powered up. The initial boot sequence can take several seconds. After the LEDs complete the diagnostic LED sequence, the option is successfully initialized. The LEDs then assume operational conditions as shown in [Table 4.3](#).

Table 4.3 Power-Up Diagnostic LED Sequence

Sequence	Module Status (MS)	Network Status (NS)	Time (ms)
1	Green	OFF	250
2	Red	OFF	250
3	Green	OFF	-
4	Green	Green	250
5	Green	Red	250
6	Green	OFF	-

5 Installation Procedure

◆ Section Safety

⚠ DANGER *Electrical Shock Hazard. Do not examine, connect, or disconnect wiring on an energized drive. Before servicing, disconnect all power to the equipment and wait for the time specified on the warning label at a minimum. The internal capacitor stays charged after the drive is de-energized. The charge indicator LED extinguishes when the DC bus voltage decreases below 50 Vdc. When all indicators are OFF, measure for dangerous voltages to make sure that the drive is safe. If you do work on the drive when it is energized, it will cause serious injury or death from electrical shock.*

⚠ WARNING *Electrical Shock Hazard. Do not operate the drive when covers are missing. Replace covers and shields before you operate the drive. Use the drive only as specified by the instructions. Some figures in this section include drives without covers or safety shields to more clearly show the inside of the drive. If covers or safety shields are missing from the drive, it can cause serious injury or death.*

⚠ WARNING *Electrical Shock Hazard. Only let approved personnel install, wire, maintain, examine, replace parts, and repair the drive. If personnel are not approved, it can cause serious injury or death.*

⚠ WARNING *Electrical Shock Hazard. Do not remove covers or touch circuit boards while the drive is energized. If you touch the internal components of an energized drive, it can cause serious injury or death.*

⚠ WARNING *Electrical Shock Hazard. Do not use damaged wires, put too much force on the wiring, or cause damage to the wire insulation. Damaged wires can cause serious injury or death.*

⚠ WARNING *Fire Hazard. Tighten all terminal screws to the correct tightening torque. Connections that are too loose or too tight can cause incorrect operation and damage to the drive. Incorrect connections can also cause death or serious injury from fire.*

NOTICE *Damage to Equipment. When you touch the option, make sure that you observe correct electrostatic discharge (ESD) procedures. If you do not follow procedures, it can cause ESD damage to the drive circuitry.*

NOTICE *Damage to Equipment. Do not de-energize the drive while the drive is outputting voltage. Incorrect equipment sequencing can cause damage to the drive.*

NOTICE *Do not operate a drive or connected equipment that has damaged or missing parts. You can cause damage to the drive and connected equipment.*

NOTICE *Use Yaskawa connection cables or recommended cables only. Incorrect cables can cause the drive or option to function incorrectly.*

NOTICE *Damage to Equipment. Correctly connect the connectors. Incorrect connections can cause malfunction or damage to the equipment.*

NOTICE *Damage to Equipment. Make sure that all connections are correct after you install the drive and connecting peripheral devices. Incorrect connections can cause damage to the option.*

◆ Procedures to Install and Wire Options on a Drive

Refer to the following table to check the procedures to install and wire the option on a drive.

Table 5.1 Procedures to Install and Wire Options on a Drive

Drive	Procedures to Install and Wire Options on a Drive	Reference Page
A1000	Procedure A	19
D1000	Procedure A	19
R1000	Procedure A	19
U1000	Procedure A	19
U1000L	Procedure A	19
Z1000U	Procedure A	19
Z1000	Procedure B	25
GA500	*1 *2	-
GA700	Procedure C	31
GA800	Procedure C	31
CR700	Procedure C	-
CH700	Procedure C	-

Drive	Procedures to Install and Wire Options on a Drive	Reference Page
HV600	Procedure D	36
FP605	Procedure D	36

*1 To install the option on GA500 drives, use the option mounting kit (JOHB-GA50) and manual.

*2 Before you install the option on a GA500 drive, make sure that the option software version is PRG: 4103 or later.

■ Procedure A

This section shows the procedure to install and wire the option on a 1000-series drive.

Prepare the Drive for the Option

Correctly wire the drive as specified by the manual packaged with the drive. Make sure that the drive functions correctly. Refer to the drive manuals for more information.

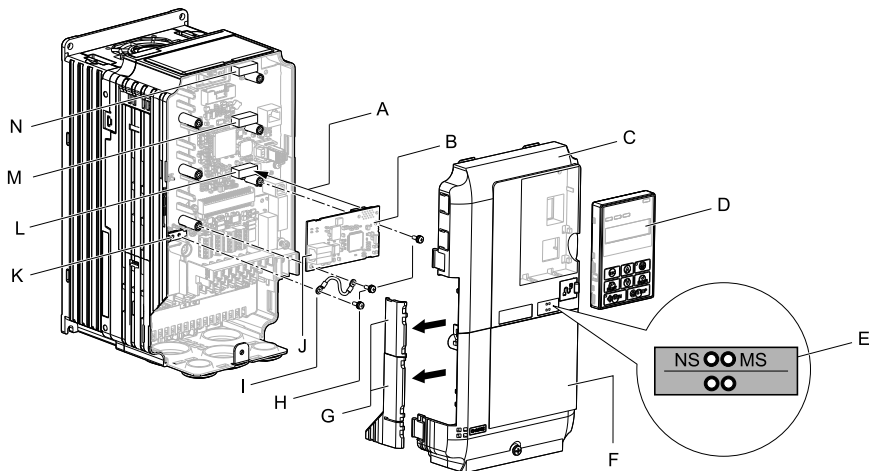

- | | |
|--|---|
| A - Insertion point for CN5 connector | H - Included screws |
| B - Option | I - Ground wire |
| C - Drive front cover | J - Option modular connector CN1 |
| D - Keypad | K - Drive grounding terminal (FE) |
| E - LED label | L - Connector CN5-A |
| F - Drive terminal cover | M - Connector CN5-B (Not available for communication option installation.) |
| G - Removable tabs for wire routing | N - Connector CN5-C (Not available for communication option installation.) |

Figure 5.1 Drive Components with Option

Install the Option

Use this procedure to install the option.

⚠ DANGER *Electrical Shock Hazard. Do not examine, connect, or disconnect wiring on an energized drive. Before servicing, disconnect all power to the equipment and wait for the time specified on the warning label at a minimum. The internal capacitor stays charged after the drive is de-energized. The charge indicator LED extinguishes when the DC bus voltage decreases below 50 Vdc. When all indicators are OFF, measure for dangerous voltages to make sure that the drive is safe. If you do work on the drive when it is energized, it will cause serious injury or death from electrical shock.*

1. Remove the keypad (B), front cover (A), and terminal cover (C).

Shut off power to the drive and wait for the time specified on the drive warning label at a minimum. Make sure that the charge indicator LED is unlit, then remove the keypad and front cover. Refer to the drive manuals for more information.

You can only install this option into the CN5-A connector on the drive control board.

NOTICE *Damage to Equipment.* When you touch the option, make sure that you observe correct electrostatic discharge (ESD) procedures. If you do not follow procedures, it can cause ESD damage to the drive circuitry.

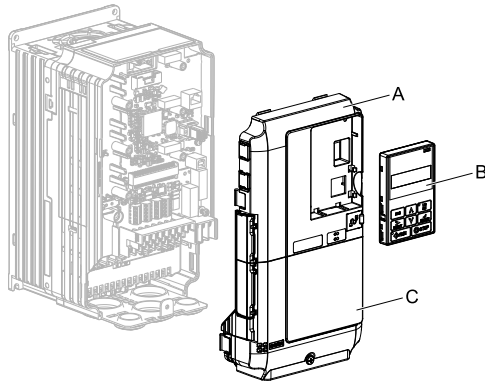

A - Drive front cover

C - Drive terminal cover

B - Keypad

Figure 5.2 Remove the Keypad, Front Cover, and Terminal Cover

- Put the LED label (B) in the correct position on the drive front cover (A).

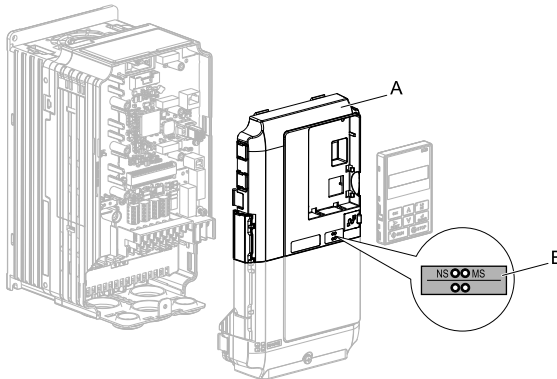

A - Drive front cover

B - LED label

Figure 5.3 Put the LED Label on the Drive Front Cover

3. Install the option (A) into the CN5-A connector (C) on the drive and use one of the included screws (B) to put it in place.

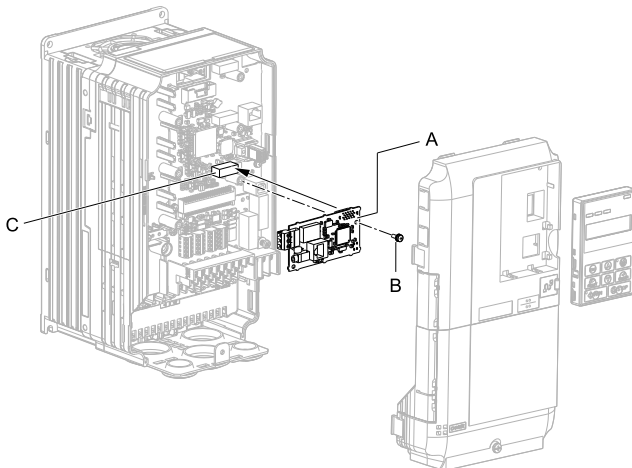

A - Option

B - Included screw

C - Connector CN5-A

Figure 5.4 Install the Option

4. Use one of the remaining included screws (B) to connect one end of the ground wire (C) to the ground terminal (D). Use the last remaining included screw (B) to connect the other end of the ground wire (C) to the remaining ground terminal and installation hole on the option (A).

Tighten the screws to a correct tightening torque:

- 0.5 N·m to 0.6 N·m (4.4 in·lb to 5.3 in·lb)

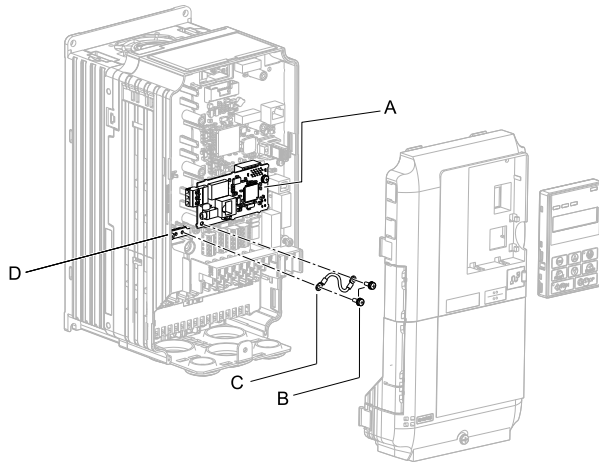

A - Option

B - Included screws

C - Ground wire

D - Drive grounding terminal (FE)

Figure 5.5 Connect the Ground Wire

Note:

The drive has only two ground terminal screw holes. When you connect three options, two options will share one ground terminal.

5. Route the option wiring.

Procedures to wire the option are different for different drive models.

- You can route the option wiring through openings on the front cover of some models. Remove the perforated tabs on the left side of the front cover as shown in [Figure 5.6-A](#) to create the necessary openings on these models. To prevent damage to the cable from the cut end, treat the cut surface with sandpaper.
- Route the option wiring inside the enclosure as shown in [Figure 5.6-B](#). Refer to the drive manuals for more information.

Note:

Isolate communication cables from main circuit wiring and other electrical and power lines.

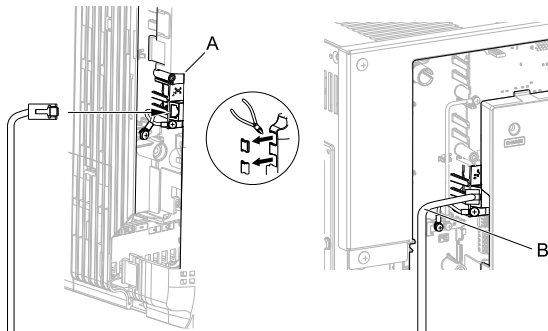

- A - Route wires through the openings provided on the left side of the front cover. *1** **B - Use the open space provided inside the drive to route option wiring.**

Figure 5.6 Wire Routing Examples

*1 If there is wiring outside the enclosure, the drive will not meet Enclosed wall-mounted type (IP20/UL Type 1) requirements.

6. Firmly connect the Ethernet communication cable to the option modular connector (CN1).

Isolate communication cables from main circuit wiring and other electrical and power lines. Make sure that you firmly connect the cable end. (Refer to [Figure 5.28](#)). Refer to [Communication Cable Specifications on page 44](#) for more information.

NOTICE *Damage to Equipment. When you touch the option, make sure that you observe correct electrostatic discharge (ESD) procedures. If you do not follow procedures, it can cause ESD damage to the drive circuitry.*

7. Reattach the front cover (A), terminal cover (C), and keypad (B).
Refer to the drive manuals for more information.

NOTICE *Do not pinch cables between the front covers and the drive. Failure to comply could cause erroneous operation.*

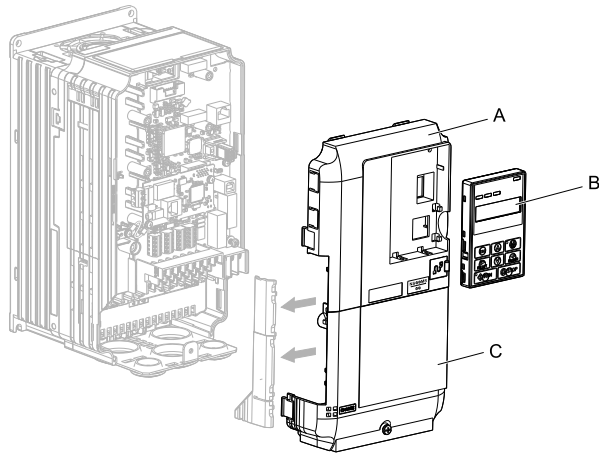

A - Drive front cover
B - Keypad

C - Drive terminal cover

Figure 5.7 Replace the Front Cover, Terminal Cover, and Keypad

8. Set drive parameters in [Related Drive Parameters on page 45](#) for correct option performance.

■ Procedure B

This section shows the procedure to install and wire the option on a Z1000 drive.

Prepare the Drive for the Option

Correctly wire the drive as specified by the manual packaged with the drive. Make sure that the drive functions correctly. Refer to the drive manuals for more information.

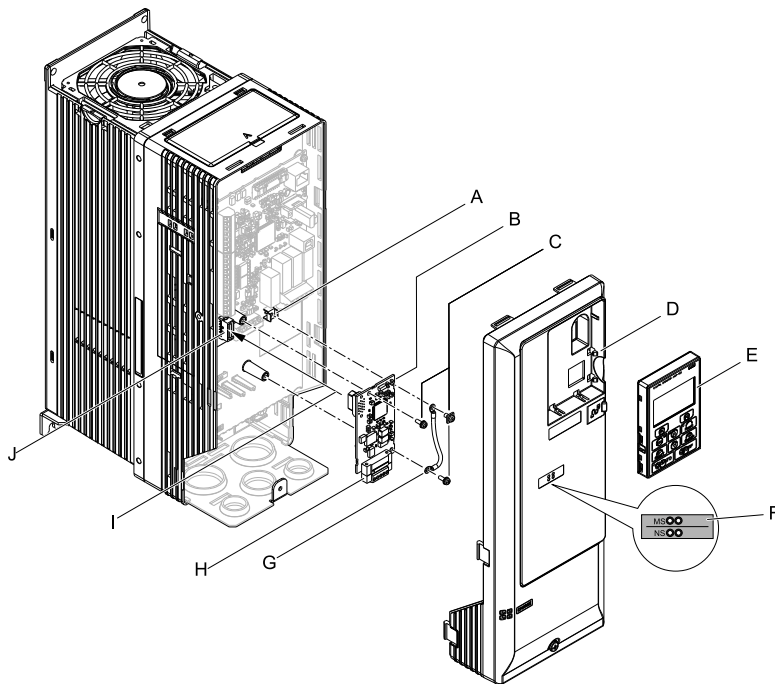

- | | |
|-----------------------------------|---------------------------------------|
| A - Drive grounding terminal (FE) | F - LED label |
| B - Option | G - Ground wire |
| C - Included screws | H - Option modular connector CN1 |
| D - Drive front cover | I - Insertion point for CN5 connector |
| E - Keypad | J - Connector CN5 |

Figure 5.8 Drive Components with Option

Install the Option

Use this procedure to install the option.

⚠ DANGER *Electrical Shock Hazard. Do not examine, connect, or disconnect wiring on an energized drive. Before servicing, disconnect all power to the equipment and wait for the time specified on the warning label at a minimum. The internal capacitor stays charged after the drive is de-energized. The charge indicator LED extinguishes when the DC bus voltage decreases below 50 Vdc. When all indicators are OFF, measure for dangerous voltages to make sure that the drive is safe. If you do work on the drive when it is energized, it will cause serious injury or death from electrical shock.*

1. Remove the keypad (B) and front cover (A).

Shut off power to the drive and wait for the time specified on the drive warning label at a minimum. Make sure that the charge indicator LED is unlit, then remove the keypad and front cover. Refer to the drive manuals for more information.

NOTICE *Damage to Equipment.* When you touch the option, make sure that you observe correct electrostatic discharge (ESD) procedures. If you do not follow procedures, it can cause ESD damage to the drive circuitry.

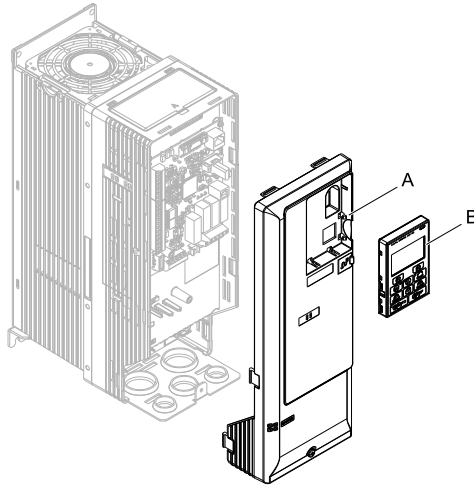

A - Drive front cover

B - Keypad

Figure 5.9 Remove the Front Cover and Keypad

- Put the LED label (B) in the correct position on the drive front cover (A).

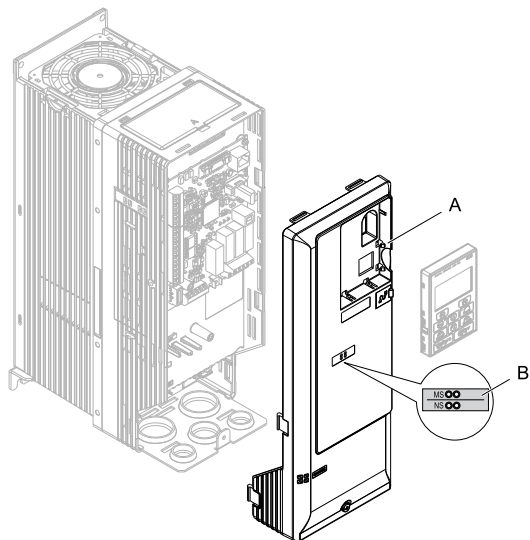

A - Drive front cover

B - LED label

Figure 5.10 Put the LED Label on the Drive Front Cover

3. Install the option (A) into the CN5 connector (C) on the drive and use one of the included screws (B) to put it in place.

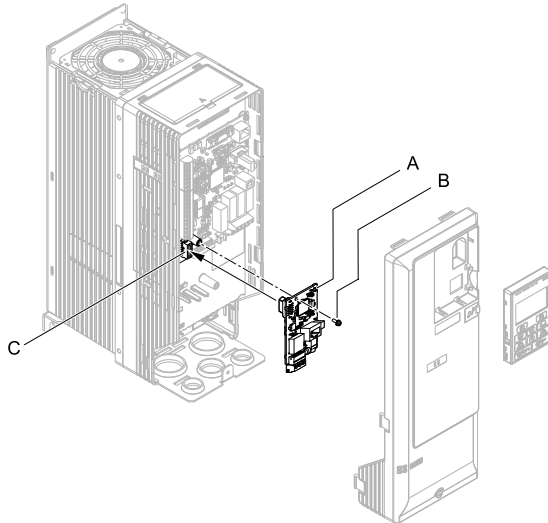

A - Option

C - Connector CN5

B - Included screw

Figure 5.11 Install the Option

4. Use one of the remaining included screws (B) to connect one end of the ground wire (C) to the ground terminal (A). Use the last remaining included screw (B) to connect the other end of the ground wire (C) to the remaining ground terminal and installation hole on the option (A).

Tighten the screws to a correct tightening torque:

- 0.5 N·m to 0.6 N·m (4.4 in·lb to 5.3 in·lb)

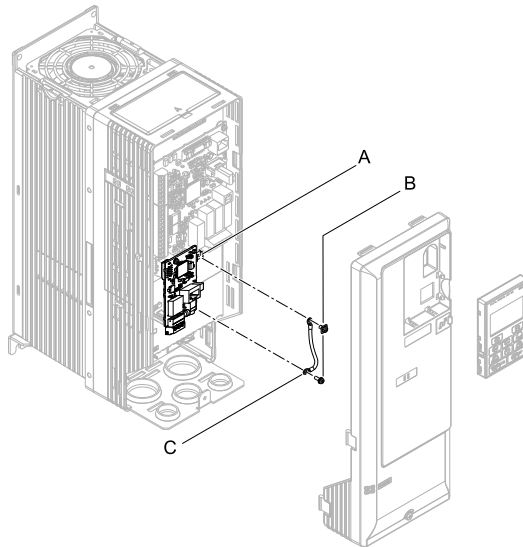

A - Drive grounding terminal (FE)

C - Ground wire

B - Included screws

Figure 5.12 Connect the Ground Wire

5. Firmly connect the Ethernet communication cable to the option modular connector (CN1).

Isolate communication cables from main circuit wiring and other electrical and power lines. Make sure that you firmly connect the cable end. (Refer to [Figure 5.28](#)). Refer to [Communication Cable Specifications on page 44](#) for more information.

NOTICE *Damage to Equipment. When you touch the option, make sure that you observe correct electrostatic discharge (ESD) procedures. If you do not follow procedures, it can cause ESD damage to the drive circuitry.*

6. Reattach the drive front cover (A) and the keypad (B).

Refer to the drive manuals for more information.

NOTICE *Do not pinch cables between the front covers and the drive. Failure to comply could cause erroneous operation.*

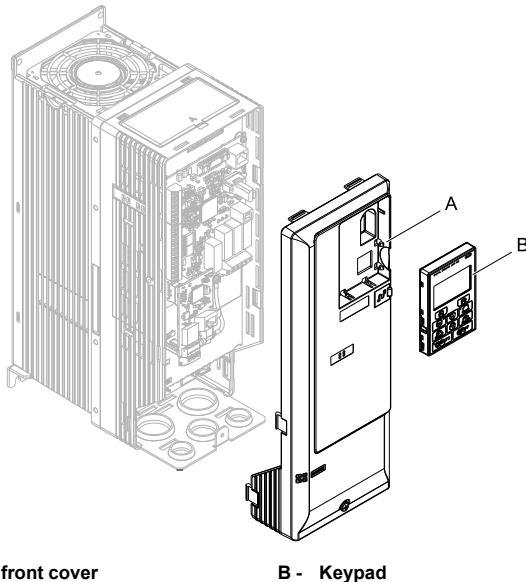

A - Drive front cover

B - Keypad

Figure 5.13 Replace the Front Cover and Keypad

7. Set drive parameters in [Related Drive Parameters on page 45](#) for correct option performance.

■ Procedure C

This section shows the procedure to install and wire the option on a GA700, GA800, CR700, or CH700 drive.

Prepare the Drive for the Option

Before you install the option on a YASKAWA AC Drive GA700, GA800, CR700, or CH700, make sure that the option software version is PRG: 4103 or later.

Correctly wire the drive as specified by the manual packaged with the drive. Make sure that the drive functions correctly. Refer to the drive manuals for more information.

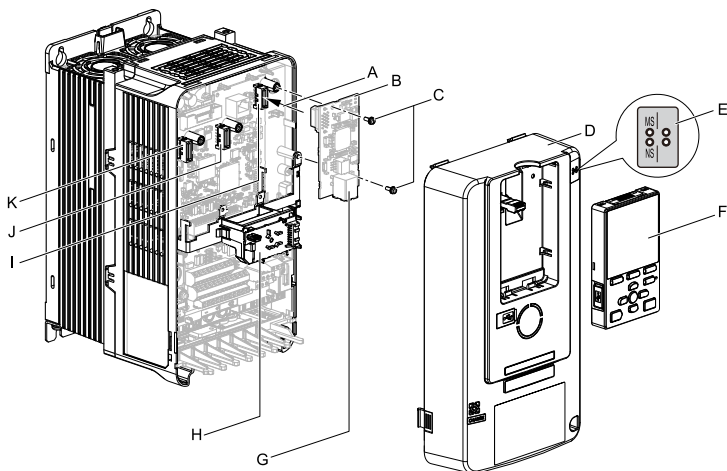

- | | |
|--|---|
| A - Insertion point for CN5 connector | G - Option modular connector CN1 |
| B - Option | H - LED Status Ring board |
| C - Included screws | I - Connector CN5-A |
| D - Drive front cover | J - Connector CN5-B (Not available for communication option installation.) |
| E - LED label | K - Connector CN5-C (Not available for communication option installation.) |
| F - Keypad | |

Figure 5.14 Drive Components with Option

Install the Option

Use this procedure to install the option.

⚠ DANGER *Electrical Shock Hazard. Do not examine, connect, or disconnect wiring on an energized drive. Before servicing, disconnect all power to the equipment and wait for the time specified on the warning label at a minimum. The internal capacitor stays charged after the drive is de-energized. The charge indicator LED extinguishes when the DC bus voltage decreases below 50 Vdc. When all indicators are OFF, measure for dangerous voltages to make sure that the drive is safe. If you do work on the drive when it is energized, it will cause serious injury or death from electrical shock.*

1. Put the LED label (A) in the correct position on the drive front cover (B).

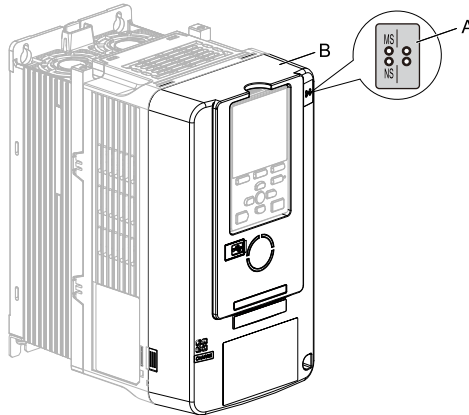

A - LED label

B - Drive front cover

Figure 5.15 Put the LED Label on the Drive Front Cover

2. Remove the keypad (E) and front cover (D).

Shut off power to the drive and wait for the time specified on the drive warning label at a minimum. Make sure that the charge indicator LED is unlit, then remove the keypad and front cover. Refer to the drive manuals for more information. You can only install this option into the CN5-A connector on the drive control board.

NOTICE *Damage to Equipment. When you touch the option, make sure that you observe correct electrostatic discharge (ESD) procedures. If you do not follow procedures, it can cause ESD damage to the drive circuitry.*

Note:

Remove the keypad, then move the keypad connector to the holder on the drive, then remove the front cover.

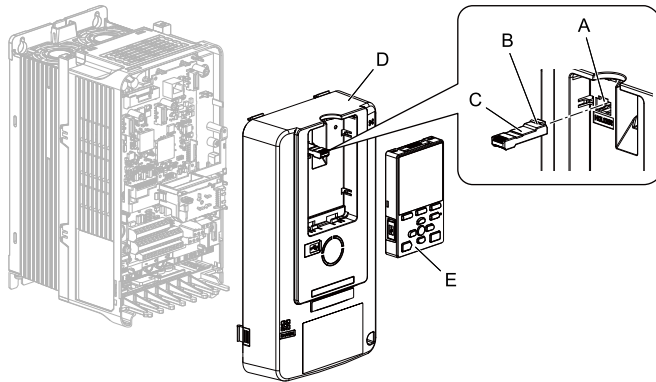

- A - Holder
- B - Keypad connector tab
- C - Keypad connector
- D - Drive front cover
- E - Keypad

Figure 5.16 Remove the Front Cover and Keypad

3. Carefully remove the LED Status Ring board (A) and put it in the temporary placement holes (B) on the right side of the drive. Refer to the drive manuals for more information.

NOTICE Do not remove the LED Status Ring board cable connector. If you disconnect the LED Status Ring board, it can cause incorrect operation and damage to the drive.

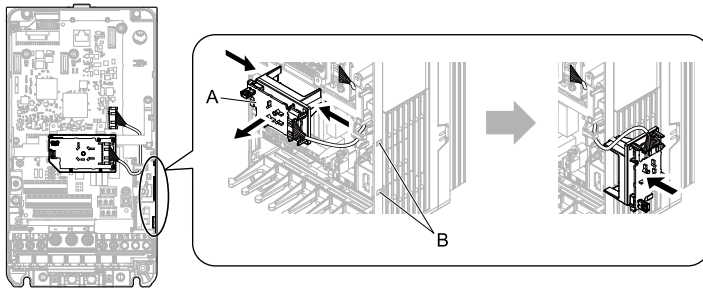

Drive front view

- A - LED Status Ring board
- B - Temporary placement holes

Figure 5.17 Remove the LED Status Ring Board

4. Install the option (A) into the CN5-A connector (C) on the drive and use the included screws (B) to put it in place.
Tighten the screws to a correct tightening torque:
 - 0.5 N·m to 0.6 N·m (4.4 in·lb to 5.3 in·lb)

Note:

1. A ground wire is not necessary. Do not use the ground wire.
2. Only two screws are necessary to install the option on GA700, GA800, CR700, and CH700 drives.
3. Three screws and one ground wire are packaged with option.

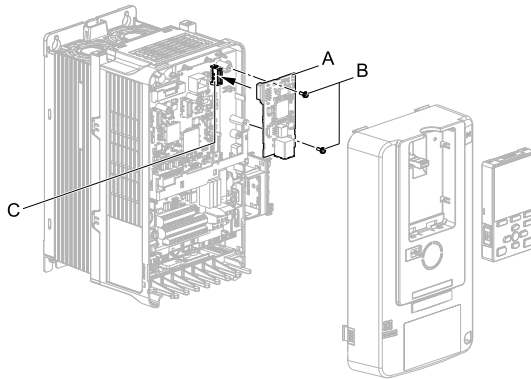
**A - Option****C - Connector CN5-A****B - Included screws****Figure 5.18 Install the Option**

5. Firmly connect the Ethernet communication cable to the option modular connector (CN1).
Isolate communication cables from main circuit wiring and other electrical and power lines. Make sure that you firmly connect the cable end. (Refer to [Figure 5.28](#)). Refer to [Communication Cable Specifications on page 44](#) for more information.

NOTICE

Damage to Equipment. When you touch the option, make sure that you observe correct electrostatic discharge (ESD) procedures. If you do not follow procedures, it can cause ESD damage to the drive circuitry.

6. Reattach the LED Status Ring board (E), front cover (C), and keypad (D).
Refer to the drive manuals for more information.

NOTICE

Do not pinch cables between the front cover or the LED Status Ring board and the drive. Failure to comply could cause erroneous operation.

Note:

- Replace the keypad connector then install the keypad.

- Put the keypad connector tab into the holder when you install the keypad connector to the holder.

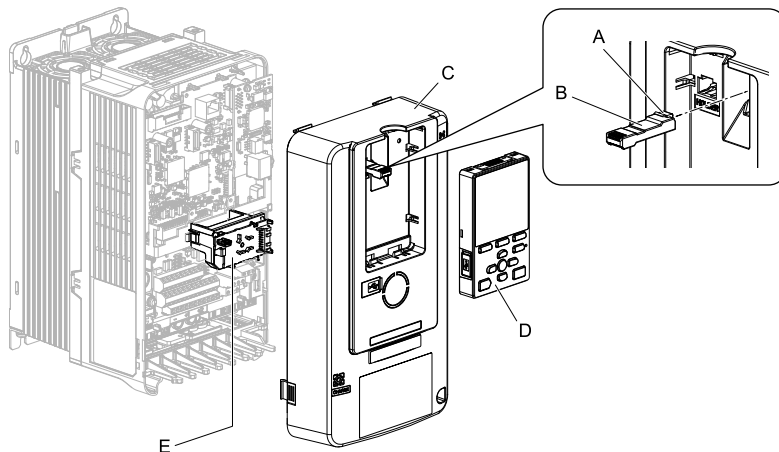

A - Keypad connector tab

B - Keypad connector

C - Drive front cover

D - Keypad

E - LED Status Ring board

Figure 5.19 Install the LED Status Ring board, Front Cover, and Keypad

7. Set drive parameters in [Related Drive Parameters on page 45](#) for correct option performance.

■ Procedure D

This section shows the procedure to install and wire the option on an HV600 or FP605 drive.

Prepare the Drive for the Option

Before you install the option on an HV600 drive, make sure that the option software version is PRG: 4103 or later.

Before you install the option on an FP605 drive, make sure that the option software version is PRG: 4106 or later.

Correctly wire the drive as specified by the manual packaged with the drive. Make sure that the drive functions correctly. Refer to the drive manuals for more information.

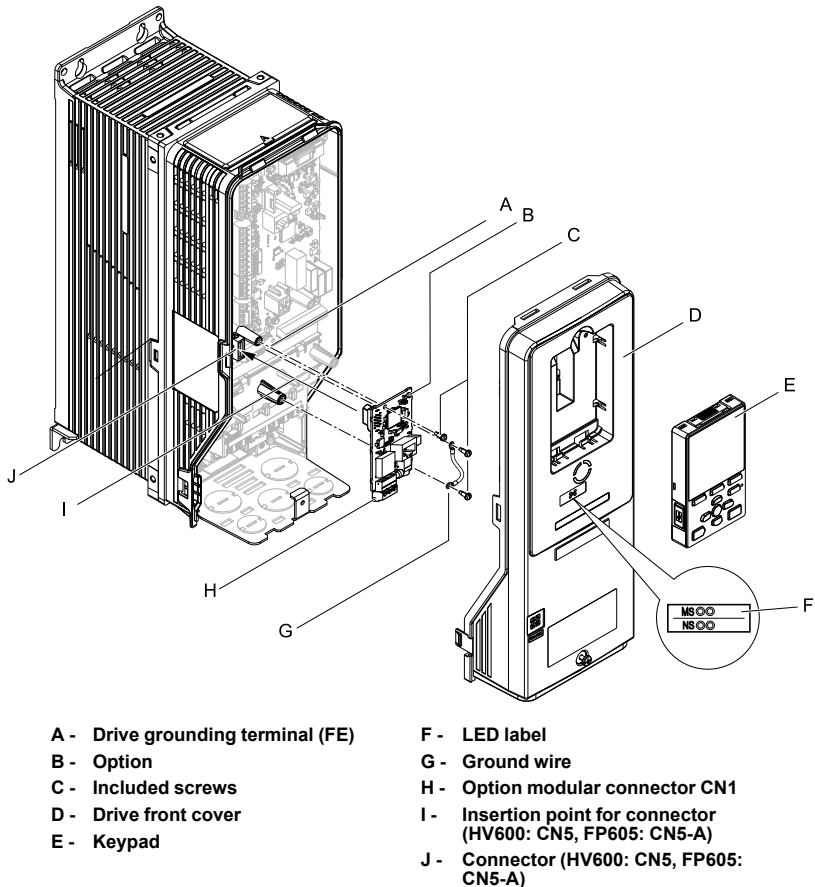

Figure 5.20 Drive Components with Option

Install the Option

Use this procedure to install the option.

⚠ DANGER *Electrical Shock Hazard. Do not examine, connect, or disconnect wiring on an energized drive. Before servicing, disconnect all power to the equipment and wait for the time specified on the warning label at a minimum. The internal capacitor stays charged after the drive is de-energized. The charge indicator LED extinguishes when the DC bus voltage decreases below 50 Vdc. When all indicators are OFF, measure for dangerous voltages to make sure that the drive is safe. If you do work on the drive when it is energized, it will cause serious injury or death from electrical shock.*

1. Remove the keypad (B) and front cover (A).

Shut off power to the drive and wait for the time specified on the drive warning label at a minimum. Make sure that the charge indicator LED is unlit, then remove the keypad and front cover. Refer to the drive manuals for more information.

NOTICE *Damage to Equipment. When you touch the option, make sure that you observe correct electrostatic discharge (ESD) procedures. If you do not follow procedures, it can cause ESD damage to the drive circuitry.*

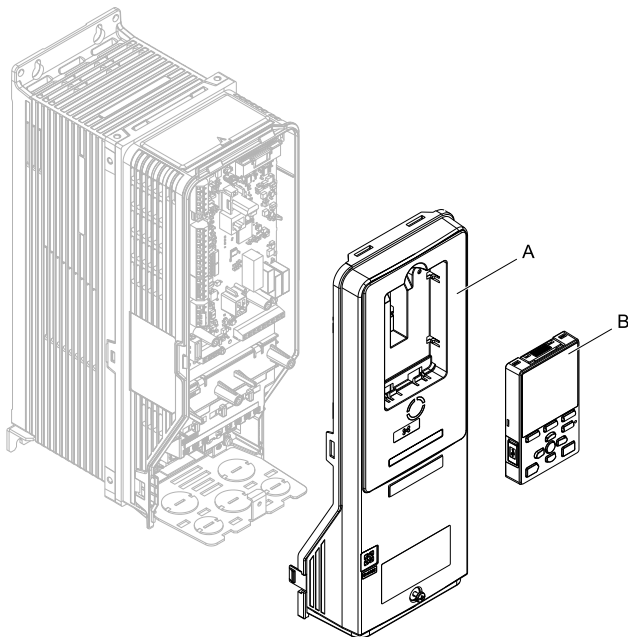

A - Drive front cover

B - Keypad

Figure 5.21 Remove the Front Cover and Keypad

- Put the LED label (B) in the correct position on the drive front cover (A).

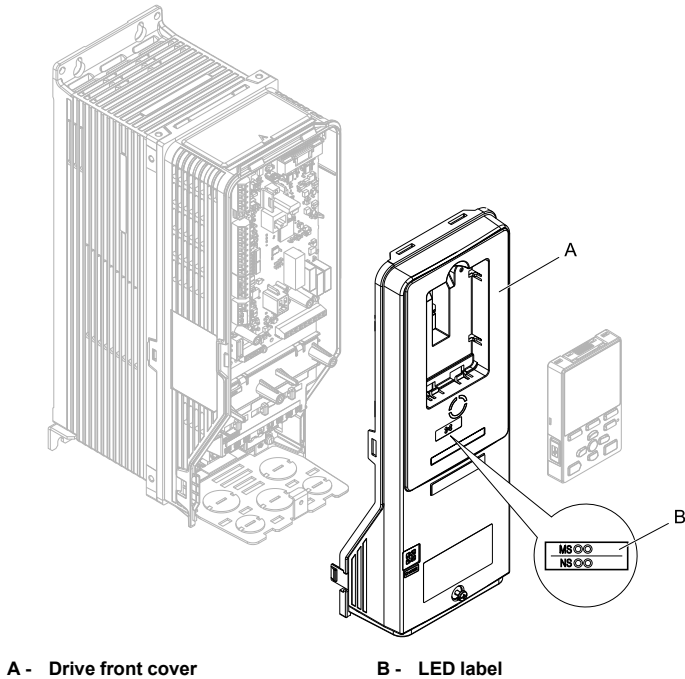

Figure 5.22 Put the LED Label on the Drive Front Cover

3. Remove the screw (B) installed in the drive grounding terminal (A).

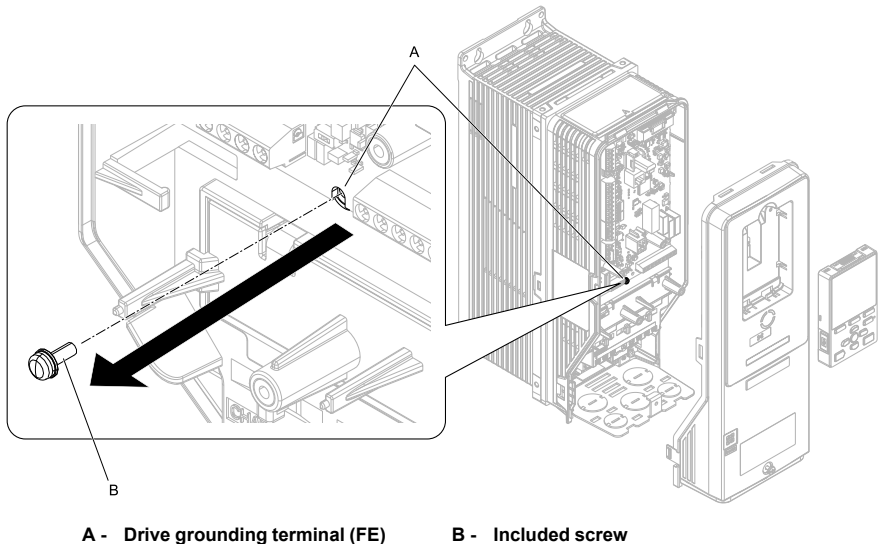
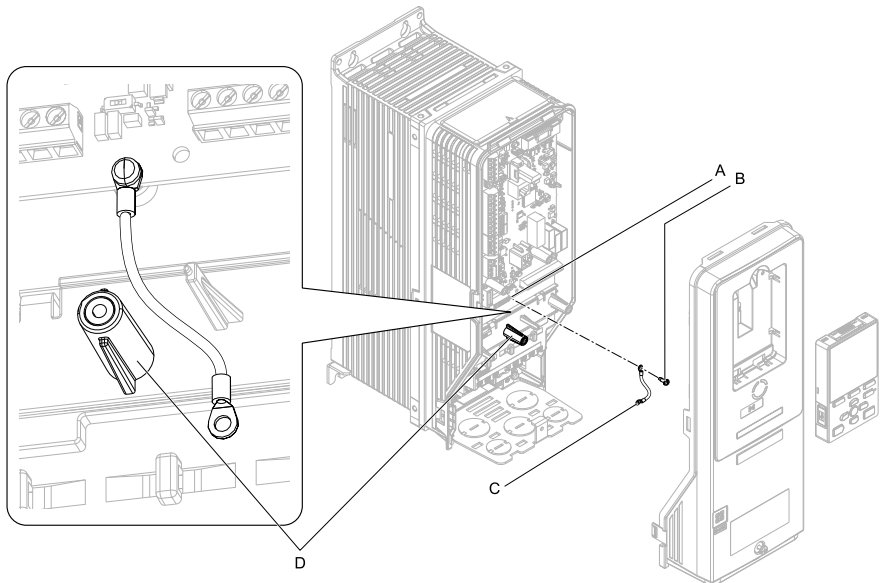

Figure 5.23 Remove the Screw from the Drive Grounding Terminal

4. Use the screw (B) installed in the FE ground terminal of the drive (A) to connect one end of the included ground wire (C) to the ground terminal on the drive.
Tighten the screw to a correct tightening torque:
 - 0.5 N·m to 0.6 N·m (4.4 in·lb to 5.3 in·lb)

Note:

Route ground wire on the right side of the stud (D).



A - Drive grounding terminal (FE)
B - Included screw

C - Ground wire
D - Stud

Figure 5.24 Connect the Ground Wire

5. Install the option (A) into the connector (C) (HV600: CN5, FP605: CN5-A) on the drive and use the included screw (B) to put it in place.
 Tighten the screw to a correct tightening torque:
 - 0.5 N·m to 0.6 N·m (4.4 in·lb to 5.3 in·lb)

Note:

1. Only two screws are necessary to install the option on HV600 and FP605 drives.
2. The option package contains three screws and one ground wire.

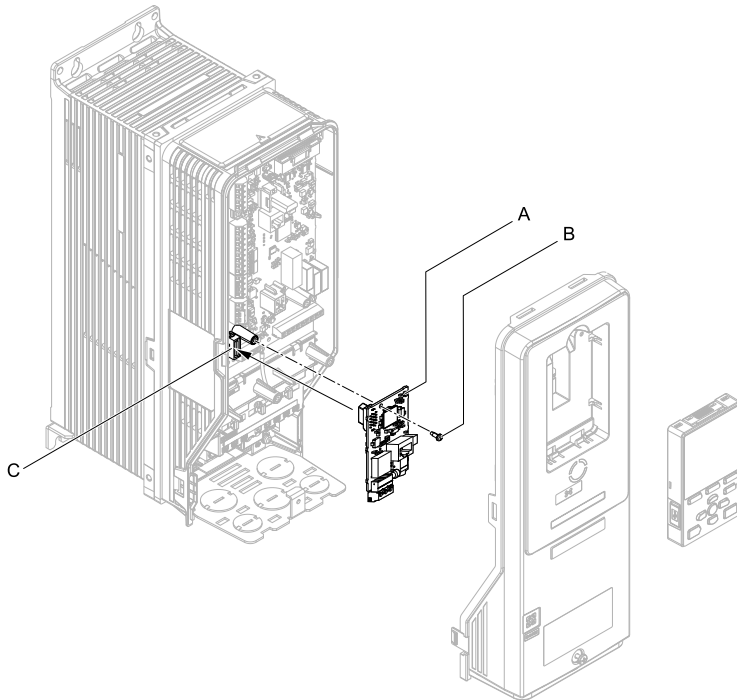

A - Option

B - Included screw

C - Connector CN5

Figure 5.25 Install the Option

6. Use one of the remaining included screws (B) to connect the ground wire (A) to the ground terminal and installation hole on the option.
Tighten the screw to a correct tightening torque:
 - 0.5 N·m to 0.6 N·m (4.4 in·lb to 5.3 in·lb)

Note:

Refer to [Figure 5.26](#) for instruction about crimp terminal orientation (C) and wire routing.

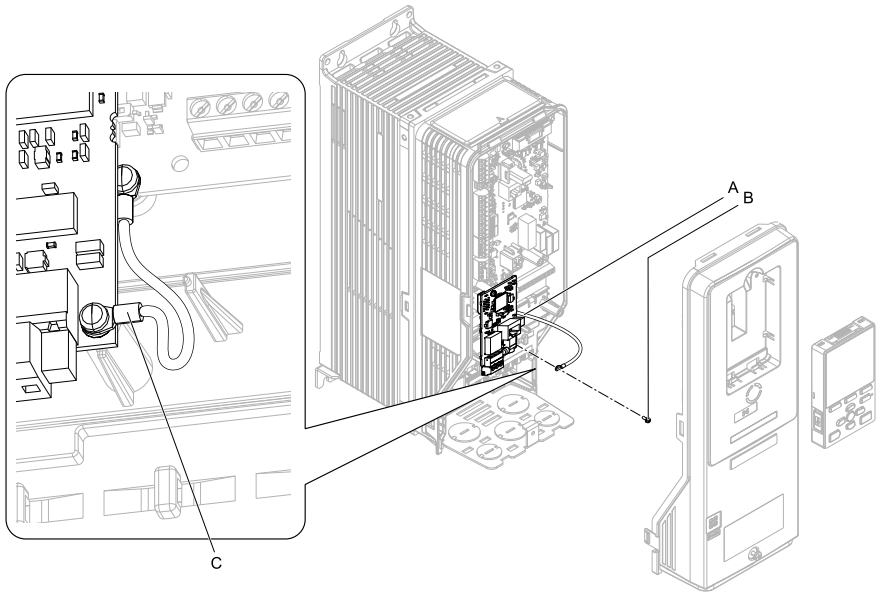

A - Ground wire
B - Included screw

C - Crimp terminal

Figure 5.26 Connect the Ground Wire

7. Firmly connect the Ethernet communication cable to the option modular connector (CN1).

Isolate communication cables from main circuit wiring and other electrical and power lines. Make sure that you firmly connect the cable end. (Refer to [Figure 5.28](#)). Refer to [Communication Cable Specifications on page 44](#) for more information.

NOTICE *Damage to Equipment.* When you touch the option, make sure that you observe correct electrostatic discharge (ESD) procedures. If you do not follow procedures, it can cause ESD damage to the drive circuitry.

8. Reattach the drive front cover (A) and the keypad (B).

Refer to the drive manuals for more information.

NOTICE *Do not pinch cables between the front covers and the drive. Failure to comply could cause erroneous operation.*

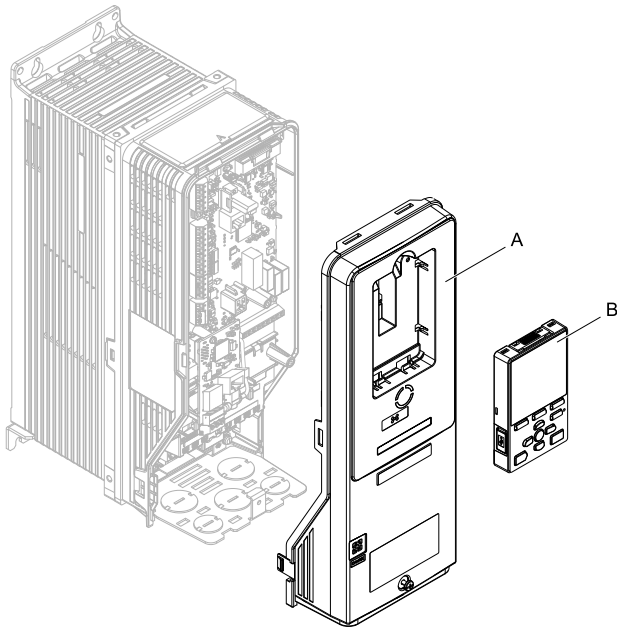

A - Drive front cover

B - Keypad

Figure 5.27 Replace the Front Cover and Keypad

9. Set drive parameters in [Related Drive Parameters on page 45](#) for correct option performance.

◆ IGMP Snooping

Switches implementing IGMP Snooping are strongly recommended. When IGMP Snooping is used, devices will only receive the multicast packets in which they are interested.

◆ Communication Cable Specifications

Yaskawa recommends using shielded Cat5e cable. The Yaskawa warranty does not cover other cable types.

◆ Option Connection Diagram

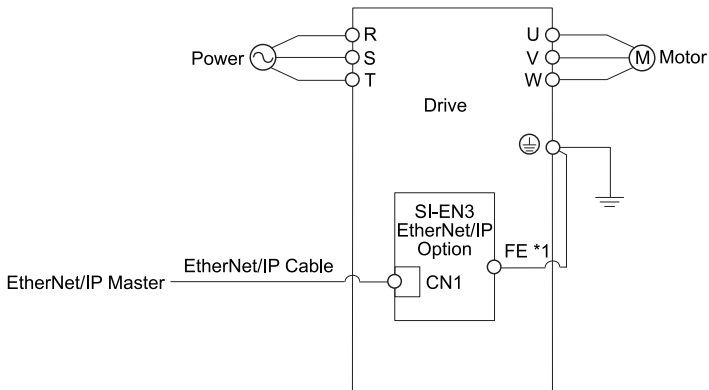

Figure 5.28 Option Connection Diagram

- *1 Connect the specified ground wire for installations on 1000-series, GA500, HV600, and FP605 drives. The ground wire is not necessary for installation on GA700, GA800, CR700, or CH700 drives.

◆ EDS Files

For easy network implementation of drives equipped with the SI-EN3, an EDS file can be obtained from: U.S.: <http://www.yaskawa.com> Europe: <http://www.yaskawa.eu.com> Japan: <http://www.e-mechatronics.com> Other areas: Check the back cover of these manuals. For questions, contact Yaskawa or a Yaskawa representative.

Note:

Download the EDS file for SI-EN3 option. The SI-EN3 will not function as a slave in the network without the appropriate EDS file.

6 Related Drive Parameters

These parameters set the drive for operation with the option. Make sure that the parameter settings in this table are correct before you start network communications.

Note:

Hex.: MEMOBUS addresses that you can use to change parameters over network communication are represented in hexadecimal numbers.

6 Related Drive Parameters

No. (Hex.)	Name	Description	Default (Range)
b1-01 (0180)	Frequency Reference Selection 1	<p>Selects the input method for frequency reference.</p> <p>0 : Keypad 1 : Analog Input 2 : Memobus/Modbus Communications 3 : Option PCB 4 : Pulse Train Input</p> <p>Note:</p> <ul style="list-style-type: none"> Set $b1-02 = 3$ [Run Command Selection 1 = Option PCB] to use the master device and serial communications to start and stop the drive. Set $b1-01 = 3$ to use the master device to control the frequency reference of the drive. The default setting is different for different drives. Refer to the instruction manual of your specific drive for more information. 	1 (0 - 4)
b1-02 (0181)	Run Command Selection 1	<p>Selects the input method for the Run command.</p> <p>0 : Keypad 1 : Digital Input 2 : Memobus/Modbus Communications 3 : Option PCB 7 : AUTO Command + Term Run 8 : AUTO Command + Serial Run 9 : AUTO Command + Option Run</p> <p>Note:</p> <ul style="list-style-type: none"> Set $b1-02 = 3$ to start and stop the drive with the master device using serial communications. Set $b1-01 = 3$ [Frequency Reference Selection 1 = Option PCB] to use the master device to control the frequency reference of the drive. Settings 7 to 9 are available in HV600 software versions PRG: 1011 and later. 	1 (0 - 9)
F6-01 (03A2)	Communication Error Selection	<p>Selects drive response when the drive detects a <i>bUS</i> [Option Communication Error] error during communications with the option.</p> <p>0 : Ramp to Stop 1 : Coast to Stop 2 : Fast Stop (Use C1-09) 3 : Alarm Only 4 : Alarm (Run at $d1-04$) 5 : Alarm - Ramp Stop</p> <p>Note:</p> <ul style="list-style-type: none"> When you set this parameter to 3 or 4, the drive will continue operation after it detects a fault. Separately prepare safety protection equipment and systems, for example fast-stop switches. 	1 (0 - 5)

No. (Hex.)	Name	Description	Default (Range)
		<ul style="list-style-type: none"> Refer to the drive manual to know if settings 4 and 5 are available. The setting range for 1000-Series drives is different for different software versions. Refer to the Peripheral Devices & Options section of the drive instruction manual for more information. Changes to this parameter take effect immediately. It is not necessary to cycle power on the drive. 	
F6-02 (03A3)	Comm External Fault (EF0) Detect	Selects the conditions at which EF0 [Option Card External Fault] is detected. 0 : Always Detected 1 : Detected during RUN Only	0 (0, 1)
F6-03 (03A4)	Comm External Fault (EF0) Select	Selects the operation of the drive when EF0 [Option Card External Fault] is detected. 0 : Ramp to Stop 1 : Coast to Stop 2 : Fast Stop (Use C1-09) 3 : Alarm Only Note: When you set this parameter to 3, the drive will continue operation after it detects a fault. Separately prepare safety protection equipment and systems, for example fast stop switches.	1 (0 - 3)
F6-06 (03A7)	Torque Reference/Limit by Comm	Sets the function that enables and disables the torque reference and torque limit received from the communication option. 0 : Disabled 1 : Enabled Note: <ul style="list-style-type: none"> Control method availability of this parameter is different for different product series. <ul style="list-style-type: none"> –1000-Series Parameter is available in A1-02 = 3, 6, 7 [Control Method Selection = Closed Loop Vector, PM Advanced Open Loop Vector, PM Closed Loop Vector]. When you enable this parameter, d5-01 [Torque Control Selection] sets the drive to read the value as the Torque Limit value or the Torque Reference value. d5-01 = 0 [Speed Control]: Torque Limit d5-01 = 1 [Torque Control]: Torque Reference In A1-02 = 6 [Control Method Selection = PM Advanced Open Loop Vector], this value is read as the Torque Limit. –GA500 Parameter is available in A1-02 = 2, 6, 8 [Control Method Selection = Open Loop Vector, PM Advanced Open Loop Vector, EZ Vector Control]. The drive reads this value as the Torque Limit. –GA700, GA800 	0 (0, 1)

No. (Hex.)	Name	Description	Default (Range)
		<p>Parameter is available when <i>A1-02 = 2, 3, 4, 6, 7, 8</i> [<i>Control Method Selection = Open Loop Vector, Closed Loop Vector, Advanced Open Loop Vector, PM Advanced Open Loop Vector, PM Closed Loop Vector, EZ Vector Control</i>].</p> <p>When you enable this parameter, <i>d5-01</i> [<i>Torque Control Selection</i>] sets the drive to read the value as the Torque Limit value or the Torque Reference value.</p> <p><i>d5-01 = 0</i> [<i>Speed Control</i>]: Torque Limit</p> <p><i>d5-01 = 1</i> [<i>Torque Control</i>]: Torque Reference</p> <p>When <i>A1-02 = 2, 8</i> [<i>Control Method Selection = Open Loop Vector, EZ Vector Control</i>], this value is read as the Torque Limit.</p> <p>–CR700, CH700</p> <p>When <i>A1-02 = 2, 3, 4</i> [<i>Control Method Selection = Open Loop Vector, Closed Loop Vector, Advanced Open Loop Vector</i>], this value is read as the Torque Limit.</p> <p>–HV600, FP605</p> <p>Torque Limit is enabled when <i>A1-02 = 8</i> [<i>Control Method Selection = EZ Vector Control</i>].</p> <ul style="list-style-type: none"> • If the PLC does not supply a torque reference or torque limit when <i>F6-06 = 1</i> [<i>Torque Reference/Limit by Comm = Enabled</i>], the motor cannot rotate. 	
F6-07 (03A8)	Multi-Step Ref @ NetRef/ ComRef	<p>0 : Disable Multi-Step References</p> <p>1 : Enable Multi-Step References</p> <p>Note:</p> <p>Default setting of <i>F6-07</i> is 1 for GA500.</p>	0 (0, 1)
F6-08 (036A)	Comm Parameter Reset @Initialize	<p>Selects whether communication-related parameters <i>F6-xx</i> and <i>F7-xx</i> are set back to original default values when you use parameter <i>A1-03</i> [<i>Initialize Parameters</i>] to initialize the drive.</p> <p>0 : No Reset - Parameters Retained</p> <p>1 : Reset - Back to Factory Default</p> <p>Note:</p> <p>When you set <i>F6-08</i> to 1 and you then use <i>A1-03</i> to initialize the drive, the drive will not change this setting value.</p>	0 (0, 1)
F6-14 (03BB)	Bus Error Auto Reset	<p>Enables and disables the automatic reset of a <i>bUS</i> [<i>Option Communication Error</i>] fault.</p> <p>0 : Disabled</p> <p>1 : Enabled</p> <p>Note:</p> <ul style="list-style-type: none"> • This parameter is not available in all 1000-series drives. • Changes to this parameter take effect immediately. It is not necessary to cycle power on the drive. 	0 (0, 1)
F6-15 (0B5B)	Comm. Option Parameters Reload	<p>Sets how the drive will enable the <i>F6-xx/F7-xx</i> communication-related parameters that you changed.</p> <p>0 : Reload at Next Power Cycle</p>	0 (0 - 2)

No. (Hex.)	Name	Description	Default (Range)
		1 : Reload Now 2 : Cancel Reload Request Note: <ul style="list-style-type: none"> • F6-15 is reset to 0 after setting 1 or 2. • The FP605 drive is compatible with option software version 4106 or later and the drives other than FP605 are compatible with option software version 4103 or later. Not available on 1000-series drives. 	
F7-01 (03E5)	IP Address 1	Sets the static/fixed IP address. Sets the most significant octet. Note: <ul style="list-style-type: none"> • This parameter is only effective when F7-13 = 0 [Address Mode at Startup = Static]. • All IP Addresses must be unique. • You must cycle power to the drive for the changes to take effect. For non-1000 series drives, you can set F6-15 = 1 [Comm. Option Parameters Reload = Reload Now]. 	192 (0 - 255)
F7-02 (03E6)	IP Address 2	Sets the static/fixed IP address. Sets the second most significant octet. Note: <ul style="list-style-type: none"> • This parameter is only effective when F7-13 = 0 [Address Mode at Startup = Static]. • All IP Addresses must be unique. • You must cycle power to the drive for the changes to take effect. For non-1000 series drives, you can set F6-15 = 1 [Comm. Option Parameters Reload = Reload Now]. 	168 (0 - 255)
F7-03 (03E7)	IP Address 3	Sets the static/fixed IP address. Sets the third most significant octet. Note: <ul style="list-style-type: none"> • This parameter is only effective when F7-13 = 0 [Address Mode at Startup = Static]. • All IP Addresses must be unique. • You must cycle power to the drive for the changes to take effect. For non-1000 series drives, you can set F6-15 = 1 [Comm. Option Parameters Reload = Reload Now]. 	1 (0 - 255)
F7-04 (03E8)	IP Address 4	Sets the static/fixed IP address. Sets the fourth most significant octet. Note: <ul style="list-style-type: none"> • This parameter is only effective when F7-13 = 0 [Address Mode at Startup = Static]. • All IP Addresses must be unique. • You must cycle power to the drive for the changes to take effect. For non-1000 series drives, you can set F6-15 = 1 [Comm. Option Parameters Reload = Reload Now]. 	20 (0 - 255)

6 Related Drive Parameters

No. (Hex.)	Name	Description	Default (Range)
F7-05 (03E9)	Subnet Mask 1	<p>Sets the static/fixed Subnet Mask. Sets the most significant octet.</p> <p>Note:</p> <ul style="list-style-type: none"> • This parameter is only effective when $F7-13 = 0$ [<i>Address Mode at Startup = Static</i>]. • All IP Addresses must be unique. • You must cycle power to the drive for the changes to take effect. For non-1000 series drives, you can set $F6-15 = 1$ [<i>Comm. Option Parameters Reload = Reload Now</i>]. 	255 (0 - 255)
F7-06 (03EA)	Subnet Mask 2	<p>Sets the static/fixed Subnet Mask. Sets the second most significant octet.</p> <p>Note:</p> <ul style="list-style-type: none"> • This parameter is only effective when $F7-13 = 0$ [<i>Address Mode at Startup = Static</i>]. • All IP Addresses must be unique. • You must cycle power to the drive for the changes to take effect. For non-1000 series drives, you can set $F6-15 = 1$ [<i>Comm. Option Parameters Reload = Reload Now</i>]. 	255 (0 - 255)
F7-07 (03EB)	Subnet Mask 3	<p>Sets the static/fixed Subnet Mask. Sets the third most significant octet.</p> <p>Note:</p> <ul style="list-style-type: none"> • This parameter is only effective when $F7-13 = 0$ [<i>Address Mode at Startup = Static</i>]. • All IP Addresses must be unique. • You must cycle power to the drive for the changes to take effect. For non-1000 series drives, you can set $F6-15 = 1$ [<i>Comm. Option Parameters Reload = Reload Now</i>]. 	255 (0 - 255)
F7-08 (03EC)	Subnet Mask 4	<p>Sets the static/fixed Subnet Mask. Parameter F7-08 sets the fourth most significant octet.</p> <p>Note:</p> <ul style="list-style-type: none"> • This parameter is only effective when $F7-13 = 0$ [<i>Address Mode at Startup = Static</i>]. • All IP Addresses must be unique. • You must cycle power to the drive for the changes to take effect. For non-1000 series drives, you can set $F6-15 = 1$ [<i>Comm. Option Parameters Reload = Reload Now</i>]. 	0 (0 - 255)
F7-09 (03ED)	Gateway Address 1	<p>Sets the static/fixed Gateway address. Sets the most significant octet.</p> <p>Note:</p> <ul style="list-style-type: none"> • This parameter is only effective when $F7-13 = 0$ [<i>Address Mode at Startup = Static</i>]. • All IP Addresses must be unique. 	192 (0 - 255)

No. (Hex.)	Name	Description	Default (Range)
		<ul style="list-style-type: none"> You must cycle power to the drive for the changes to take effect. For non-1000 series drives, you can set $F6-15 = 1$ [Comm. Option Parameters Reload = Reload Now]. 	
F7-10 (03EE)	Gateway Address 2	<p>Sets the static/fixed Gateway address. Sets the second most significant octet.</p> <p>Note:</p> <ul style="list-style-type: none"> This parameter is only effective when $F7-13 = 0$ [Address Mode at Startup = Static]. All IP Addresses must be unique. You must cycle power to the drive for the changes to take effect. For non-1000 series drives, you can set $F6-15 = 1$ [Comm. Option Parameters Reload = Reload Now]. 	168 (0 - 255)
F7-11 (03EF)	Gateway Address 3	<p>Sets the static/fixed Gateway address. Sets the third most significant octet.</p> <p>Note:</p> <ul style="list-style-type: none"> This parameter is only effective when $F7-13 = 0$ [Address Mode at Startup = Static]. All IP Addresses must be unique. You must cycle power to the drive for the changes to take effect. For non-1000 series drives, you can set $F6-15 = 1$ [Comm. Option Parameters Reload = Reload Now]. 	1 (0 - 255)
F7-12 (03F0)	Gateway Address 4	<p>Sets the static/fixed Gateway address. Parameter F7-12 sets the fourth most significant octet.</p> <p>Note:</p> <ul style="list-style-type: none"> This parameter is only effective when $F7-13 = 0$ [Address Mode at Startup = Static]. All IP Addresses must be unique. You must cycle power to the drive for the changes to take effect. For non-1000 series drives, you can set $F6-15 = 1$ [Comm. Option Parameters Reload = Reload Now]. 	1 (0 - 255)
F7-13 (03F1)	Address Startup Mode	<p>Selects how the option address is set.</p> <p>0 : Static (Use F7-01 to F7-12 to set.) 1 : BOOTP (Use network address.) 2 : DHCP (Use network address.)</p> <p>Note:</p> <p>You must cycle power to the drive for the changes to take effect. For non-1000 series drives, you can set $F6-15 = 1$ [Comm. Option Parameters Reload = Reload Now].</p>	2 (0 - 2)
F7-14 (03F2)	Duplex Mode Selection	<p>Selects duplex mode setting.</p> <p>0 : Half/Half 1 : Auto/Auto</p>	1 (0 - 8)

No. (Hex.)	Name	Description	Default (Range)
		2 : Full/Full 3 : Half/Auto 4 : Half/Full 5 : Auto/Half 6 : Auto/Full 7 : Full/Half 8 : Full/Auto Note: <ul style="list-style-type: none"> • When you set this parameter to 0, 2, 3, 4, 7, or 8, you must also set F7-15 [Communication Speed Selection]. • The option sets the duplex mode as specified by these F7-14 settings: <ul style="list-style-type: none"> –0: Half/Half, 3: Half/Auto, 4: Half/Full, duplex mode is "Half". –1: Auto/Auto, 5: Auto/Half, 6: Auto/Full, duplex mode is "Auto". –2: Full/Full, 7: Full/Half, 8: Full/Auto, duplex mode is "Full". 	
F7-15 (03F3)	Communication Speed Selection	Sets the communications speed. 10 : 10/10 Mbps 100 : 100/100 Mbps 101 : 10/100 Mbps 102 : 100/10 Mbps Note: <ul style="list-style-type: none"> • F7-15 is only effective when the port is set to half or full duplex in F7-14 [Duplex Mode Selection]. • The default setting and setting range are different for different product series. <ul style="list-style-type: none"> –1000-Series, GA700, GA800, CR700, CH700 Drives Default value: 10 Range: 10 - 102 –GA500 Default value: 10 Range: 10, 100 –HV600, FP605 Default value: 10 Range: 10, 102 • This option sets the communication speed as specified by these F7-15 settings: <ul style="list-style-type: none"> –10: 10/10 Mbps or 101: 10/100 Mbps, the speed is 10 Mbps. –100: 100/100 Mbps or 102: 100/10 Mbps, the speed is 100 Mbps. 	10 (10 - 102)
F7-16 (03F4)	Timeout Value	Sets the detection time for a communications timeout. Note: <ul style="list-style-type: none"> • Set this parameter to 0.0 to disable the connection timeout function. 	0.0 s (0.0 s - 30.0 s)

No. (Hex.)	Name	Description	Default (Range)
		<ul style="list-style-type: none"> This parameter is not available in all 1000-series drives. Changes to this parameter take effect immediately. It is not necessary to cycle power on the drive. 	
F7-17 (03F5)	EtherNet/IP Speed Scaling Factor	<p>Sets the scaling factor for the speed monitor in EtherNet/IP Class ID 2A (Hex.) Object.</p> <p>Note: Changes to this parameter take effect immediately. It is not necessary to cycle power on the drive.</p>	0 (-15 - 15)
F7-18 (03F6)	EtherNet/IP Current Scale Factor	<p>Sets the scaling factor for the output current monitor in EtherNet/IP Class ID 2A (Hex.) Object.</p> <p>Note: Changes to this parameter take effect immediately. It is not necessary to cycle power on the drive.</p>	0 (-15 - 15)
F7-19 (03F7)	EtherNet/IP Torque Scale Factor	<p>Sets the scaling factor for the torque monitor in EtherNet/IP Class ID 2A (Hex.) Object.</p> <p>Note: Changes to this parameter take effect immediately. It is not necessary to cycle power on the drive.</p>	0 (-15 - 15)
F7-20 (03F8)	EtherNet/IP Power Scaling Factor	<p>Sets the scaling factor for the power monitor in EtherNet/IP Class ID 2A (Hex.) Object.</p> <p>Note: Changes to this parameter take effect immediately. It is not necessary to cycle power on the drive.</p>	0 (-15 - 15)
F7-21 (03F9)	EtherNet/IP Voltage Scale Factor	<p>Sets the scaling factor for the voltage monitor in EtherNet/IP Class ID 2A (Hex.) Object.</p> <p>Note: Changes to this parameter take effect immediately. It is not necessary to cycle power on the drive.</p>	0 (-15 - 15)
F7-22 (03FA)	EtherNet/IP Time Scaling	<p>Sets the scaling factor for the time monitor in EtherNet/IP Class ID 2A (Hex.) Object.</p> <p>Note: Changes to this parameter take effect immediately. It is not necessary to cycle power on the drive.</p>	0 (-15 - 15)

6 Related Drive Parameters

No. (Hex.)	Name	Description	Default (Range)
F7-23 - F7-27 (03FB - 03FF) F7-28 - F7-32 (0370 - 0374)	Dynamic Output Assembly Parameters 1 to 10	Parameters used in Output Assemblies 116, 117, 118, 119, 120. Each parameter contains a MEMOBUS/Modbus address. The value received for the Output Assembly will be written to this corresponding MEMOBUS/Modbus address. A MEMOBUS/Modbus address value of 0 means that the value received for the Output Assembly will not be written to any MEMOBUS/Modbus register.	0 (-)
F7-33 - F7-42 (0375 to 037E)	Dynamic Input Assembly Parameters 1 to 10	Parameters used in Input Assemblies 166, 167, 168, 169, 170. Each parameter contains a MEMOBUS/Modbus address. The value sent for the Input Assembly will be read from this corresponding MEMOBUS/Modbus address. A MEMOBUS/Modbus address value of 0 means that the value sent for the Input Assembly is not defined by the user, therefore the option default register value will be returned.	0 (-)

Table 6.1 Option Monitor

No.	Name	Description	Range
U6-80 - U6-83	Option IP Address 1 - 4	Shows the currently available local IP Address. <ul style="list-style-type: none"> • U6-80: First octet • U6-81: Second octet • U6-82: Third octet • U6-83: Forth octet 	0 - 255
U6-84 - U6-87	Online Subnet 1 - 4	Shows the currently available subnet mask. <ul style="list-style-type: none"> • U6-84: First octet • U6-85: Second octet • U6-86: Third octet • U6-87: Forth octet 	0 - 255
U6-88 - U6-91	Online Gateway 1 - 4	Shows the currently available gateway address. <ul style="list-style-type: none"> • U6-88: First octet • U6-89: Second octet • U6-90: Third octet • U6-91: Forth octet 	0 - 255
U6-92	Online Speed	Shows the currently available communications speed.	10: 10 Mbps 100: 100 Mbps
U6-93	Online Duplex	Shows duplex setting currently available.	0: Half/Half 1: Full/Full
U6-97	OPT SPARE 4	Shows option software version.	-

No.	Name	Description	Range
U6-98	First Fault	Shows first option fault. Refer to page 74 for more information.	-
U6-99	Current Fault	Shows current option fault. Refer to page 74 for more information.	-

7 EtherNet/IP Configuring Messaging

This section provides information on methods used to control the drive and converter with the option installed.

◆ Drive Polled Configuration

The assemblies in [Table 7.1](#) are available for polled I/O:

Table 7.1 Supported Polled I/O Assemblies

Assembly Number (Hex.)	Description	Type	Bytes	Page
20 (14)	EtherNet/IP Basic Speed Control Output	Output	4	58
21 (15)	EtherNet/IP Extended Speed Control Output	Output	4	58
22 (16)	EtherNet/IP Speed and Torque Control Output	Output	6	-
23 (17)	EtherNet/IP Extended Speed and Torque Control Output	Output	6	-
70 (46)	EtherNet/IP Basic Speed Control Input	Input	4	60
71 (47)	EtherNet/IP Extended Speed Control Input	Input	4	60
72 (48)	EtherNet/IP Speed and Torque Control Input	Input	6	-
73 (49)	EtherNet/IP Extended Speed and Torque Control Input	Input	6	-
100 (64)	(Vendor Specific Yaskawa Electric (YE) Assy) MEMOBUS Message Output	Output	5	-
101 (65)	(Vendor Specific Yaskawa Electric (YE) Assy) Speed/Torque Control Output	Output	8	-
115 (73)	(Vendor Specific Yaskawa Electric (YE) Assy) Extended Speed/Torque Control Output	Output	40	-
116 (74)	(Vendor Specific Yaskawa Electric (YE) Assy) High Speed/Torque Control Output	Output	44	-
117 (75)	(Vendor Specific Yaskawa Electric (YE) Assy) 8-Byte Dynamic Output	Output	8	-

Assembly Number (Hex.)	Description	Type	Bytes	Page
118 (76)	(Vendor Specific Yaskawa Electric (YE) Assy) 12-Byte Dynamic Output	Output	12	-
119 (77)	(Vendor Specific Yaskawa Electric (YE) Assy) 18-Byte Dynamic Output	Output	18	-
120 (78)	(Vendor Specific Yaskawa Electric (YE) Assy) 24-Byte Dynamic Output	Output	24	-
150 (96)	(Vendor Specific Yaskawa Electric (YE) Assy) MEMOBUS Message Input	Input	5	-
151 (97)	(Vendor Specific Yaskawa Electric (YE) Assy) Speed/Torque Status Input	Input	8	-
155 (9B)	(Vendor Specific Yaskawa Electric (YE) Assy) Extended Speed/Torque Status Input	Input	40	-
166 (A6)	(Vendor Specific Yaskawa Electric (YE) Assy) High Speed/Torque Status Input	Input	44	-
167 (A7)	(Vendor Specific Yaskawa Electric (YE) Assy) 8-Byte Dynamic Input	Input	8	-
168 (A8)	(Vendor Specific Yaskawa Electric (YE) Assy) 12-Byte Dynamic Input	Input	12	-
169 (A9)	(Vendor Specific Yaskawa Electric (YE) Assy) 18-Byte Dynamic Input	Input	18	-
170 (AA)	(Vendor Specific Yaskawa Electric (YE) Assy) 24-Byte Dynamic Input	Input	24	-

◆ Converter Polled Configuration

The assemblies in [Table 7.2](#) are available for polled I/O:

Note:

These assemblies are available in D1000 and R1000.

Table 7.2 Supported Polled I/O Assemblies

Assembly Number (Hex.)	Description	Type	Bytes	Page
20 (14)	EtherNet/IP Basic Speed Control Output	Output	4	62
21 (15)	EtherNet/IP Extended Speed Control Output	Output	4	63
22 (16)	EtherNet/IP Speed and Torque Control Output	Output	6	-

Assembly Number (Hex.)	Description	Type	Bytes	Page
23 (17)	EtherNet/IP Extended Speed and Torque Control Output	Output	6	-
70 (46)	EtherNet/IP Basic Speed Control Input	Input	4	64
71 (47)	EtherNet/IP Extended Speed Control Input	Input	4	65
72 (48)	EtherNet/IP Speed and Torque Control Input	Input	6	-
73 (49)	EtherNet/IP Extended Speed and Torque Control Input	Input	6	-
101 (65)	(Vendor Specific Yaskawa Electric (YE) Assy) Speed/Torque Control Output	Output	8	-
115 (73)	(Vendor Specific Yaskawa Electric (YE) Assy) Extended Speed/Torque Control Output	Output	40	-
116 (74)	(Vendor Specific Yaskawa Electric (YE) Assy) High Speed/Torque Control Output	Output	44	-
117 (75)	(Vendor Specific Yaskawa Electric (YE) Assy) 8-Byte Dynamic Output 2	Output	8	-
118 (76)	(Vendor Specific Yaskawa Electric (YE) Assy) 12-Byte Dynamic Output 4	Output	12	-
119 (77)	(Vendor Specific Yaskawa Electric (YE) Assy) 18-Byte Dynamic Output 7	Output	18	-
120 (78)	(Vendor Specific Yaskawa Electric (YE) Assy) 24-Byte Dynamic Output 10	Output	24	-
151 (97)	(Vendor Specific Yaskawa Electric (YE) Assy) Speed/Torque Status Input	Input	8	-
155 (9B)	(Vendor Specific Yaskawa Electric (YE) Assy) Extended Speed/Torque Status Input	Input	40	-
166 (A6)	(Vendor Specific Yaskawa Electric (YE) Assy) High Speed/Torque Status Input	Input	44	-
167 (A7)	(Vendor Specific Yaskawa Electric (YE) Assy) 8-Byte Dynamic Input 2	Input	8	-
168 (A8)	(Vendor Specific Yaskawa Electric (YE) Assy) 12-Byte Dynamic Input 4	Input	12	-
169 (A9)	(Vendor Specific Yaskawa Electric (YE) Assy) 18-Byte Dynamic Input 7	Input	18	-
170 (AA)	(Vendor Specific Yaskawa Electric (YE) Assy) 24-Byte Dynamic Input 10	Input	24	-

8 Output Assemblies (Drive Consumes)

Note:

The convention in this manual is from the PLC perspective. As such, an assembly is called an “Output Assembly” when outputted from the PLC and received by this node. This section details “Output Assemblies” that are “Consumed” by the drive.

◆ EtherNet/IP Basic Speed Control Output - 20 (0x14)

Output Instance	Word	Byte	Bit 7	Bit 6	Bit 5	Bit 4	Bit 3	Bit 2	Bit 1	Bit 0	
20	0	0	-	-	-	-	-	Fault Reset	-	Run Fwd	
		1	-								
	1	2	Speed Reference (Low Byte)								
		3	Speed Reference (High Byte)								

Name	Description
Run Fwd	Forward Run Command 0: Stop 1: Forward Run
Fault Reset	Fault Reset 0: - 1: Fault Reset
Speed Reference	Speed Command Sets drive speed reference. Speed reference data: Frequency reference/2 ^{SS} (SS: Speed scale) Setting range: 0 - FFFF (Hex.) For example, when setting a reference of 4096 with a speed scale of 2: Speed reference data = $4096/2^2 = 1024 = 400$ (Hex.) Unit depends on o1-03.

◆ EtherNet/IP Extended Speed Control Output - 21 (0x15)

Output Instance	Word	Byte	Bit 7	Bit 6	Bit 5	Bit 4	Bit 3	Bit 2	Bit 1	Bit 0
21	0	0	-	NetRef	NetCtrl	-	-	Fault Reset	Run Rev	Run Fwd
		1	-							

Output Instance	Word	Byte	Bit 7	Bit 6	Bit 5	Bit 4	Bit 3	Bit 2	Bit 1	Bit 0
	1	2	Speed Reference (Low Byte)							
		3	Speed Reference (High Byte)							

Name	Description
Run Fwd	Forward Run Command 0: Stop 1: Forward Run
Run Rev	Reverse Run Command 0: Stop 1: Reverse Run
Fault Reset	Fault Reset 0: - 1: Fault Reset
NetCtrl	Run command from network 0: Depends on b1-02 1: Enables the Run command from network
NetRef	Speed reference from network 0: Depends on b1-01 1: Enables the speed reference from network
Speed Reference	Speed Command Sets drive speed reference. Speed reference data: Frequency reference/ 2^{SS} (SS: Speed scale) Setting range: 0 - FFFF (Hex.) For example, when setting a reference of 4096 with a speed scale of 2: Speed reference data = $4096/2^2 = 1024 = 400$ (Hex.) Unit depends on o1-03.

9 Input Assemblies (Drive Produces)

Note:

The convention in this manual is from the PLC perspective. An "Input Assembly" is outputted from this node and read by the PLC. This section details "Input Assemblies" that are "Produced" by the drive.

◆ EtherNet/IP Basic Speed Control Input - 70 (0x46)

Input Instance	Word	Byte	Bit 7	Bit 6	Bit 5	Bit 4	Bit 3	Bit 2	Bit 1	Bit 0	
70	0	0	-	-	-	-	-	Running 1 (FWD)	-	Faulted	
		1	-								
	1	2	Speed Actual (Low Byte)								
		3	Speed Actual (High Byte)								

Name	Description
Faulted	Faulted 0: No Fault 1: Fault
Running 1 (FWD)	Forward Running 0: Stop or Reverse Running 1: Forward Running
Speed Actual	Actual Drive Speed Monitors drive output frequency. Speed actual data: Output frequency x 2 ^{SS} (SS: Speed scale) Range: 0 - FFFF (Hex.) For example, when output frequency of 1024 with a speed scale of 2: Speed actual data = 1024 x 2 ² = 4096 = 1000 (Hex.) Unit depends on o1-03.

◆ EtherNet/IP Extended Speed Control Input - 71 (0x47)

Input Instance	Word	Byte	Bit 7	Bit 6	Bit 5	Bit 4	Bit 3	Bit 2	Bit 1	Bit 0	
71	0	0	Speed Agree	NetRef	NetCtrl	Ready	Running 2 (REV)	Running 1 (FWD)	Alarm	Faulted	
		1	State								
	1	2	Speed Actual (Low Byte)								
		3	Speed Actual (High Byte)								

Name	Description
Faulted	Faulted 0: No Fault 1: Fault
Alarm	Alarm 0: No Alarm 1: Alarm
Running 1 (FWD)	Forward Running 0: Stop or Reverse Running 1: Forward Running
Running 2 (REV)	Reverse Running 0: Stop or Forward Running 1: Reverse Running
Ready	Ready 0: Not Ready 1: Ready
NetCtrl	Run command is from network 0: Run command is not from network 1: Run command is from network
NetRef	Speed reference is from network 0: Speed reference is not from network 1: Speed reference is from network
Speed Agree	Speed Agree 0: - 1: Speed actual at speed reference
State	Contains the value from the Control Supervisor (Class 0x29) Instance 1 Attribute 6.
Speed Actual	Actual Drive Speed Monitors drive output frequency. Speed actual data: Output frequency x 2 ^{SS} (SS: Speed scale) Range: 0 - FFFF (Hex.) For example, when output frequency of 1024 with a speed scale of 2: Speed actual data = 1024 x 2 ² = 4096 = 0x1000 Unit depends on o1-03.

10 Output Assemblies (Converter Consumes)

Note:

The convention in this manual is from the PLC perspective. As such, an assembly is called an “Output Assembly” when outputted from the PLC and received by this node. This section details “Output Assemblies” that are “Consumed” by the converter.

◆ EtherNet/IP Basic Speed Control Output - 20 (0x14)

Output Instance	Word	Byte	Bit 7	Bit 6	Bit 5	Bit 4	Bit 3	Bit 2	Bit 1	Bit 0	
20	0	0	-	-	-	-	-	Fault Reset	-	D1000: Run R1000: Auto Run	
		1	-								
	1	2	D1000: Voltage Reference (Low Byte) R1000: -								
		3	D1000: Voltage Reference (High Byte) R1000: -								

Name	Description
D1000: Run R1000: Auto Run	D1000: Run converter 0: Stop 1: Run R1000: Run converter in auto 0: Stop 1: Auto Run
Fault Reset	Fault Reset 0: - 1: Fault Reset
D1000: Voltage Reference (High Byte) R1000: -	D1000: Voltage Reference Sets converter voltage reference. Voltage reference data: Voltage reference/2VS (VS: Voltage scale) Setting range: 0 - FFFF (Hex.) Example: setting a reference of 4096 with a voltage scale of 2: Voltage reference data = $4096/2^2 = 1024 = 400$ (Hex.) Unit depends on <i>o1-03</i> . R1000: -

◆ EtherNet/IP Extended Speed Control Output - 21 (0x15)

Output Instance	Word	Byte	Bit 7	Bit 6	Bit 5	Bit 4	Bit 3	Bit 2	Bit 1	Bit 0	
21	0	0	-	D1000: NetRef R1000: -	NetCtrl	-	-	Fault Reset	D1000: - R1000: Forced Run	D1000: Run R1000: Auto Run	
		1	-								
	1	2	D1000: Voltage Reference (Low Byte) R1000: -								
		3	D1000: Voltage Reference (High Byte) R1000: -								

Name	Description
D1000: Run R1000: Auto Run	D1000: Run converter 0: Stop 1: Run R1000: Run converter in auto 0: Stop 1: Auto Run
D1000: - R1000: Forced Run	D1000: - R1000: Force Run converter 0: Stop 1: Force Run
Fault Reset	Fault Reset 0: - 1: Fault Reset
NetCtrl	Run command is from network 0: Depends on b1-02 1: Run command is from network

11 Input Assemblies (Converter Produces)

Name	Description
D1000: NetRef R1000: -	D1000: Voltage command is from network 0: Depends on <i>b1-01</i> 1: Voltage command is from network R1000: -
D1000: Voltage Reference R1000: -	D1000: Voltage Reference Sets converter voltage reference. Voltage reference data: Voltage reference/2VS (VS: Voltage scale) Setting range: 0 - FFFF (Hex.) Example: setting a reference of 4096 with a voltage scale of 2: Voltage reference data = $4096/2^2 = 1024 = 400$ (Hex.) Unit depends on <i>o1-03</i> . R1000: -

11 Input Assemblies (Converter Produces)

Note:

The convention in this manual is from the PLC perspective. An “Input Assembly” is outputted from this node and read by the PLC. This section details “Input Assemblies” that are “Produced” by the converter.

◆ EtherNet/IP Basic Speed Control Input - 70 (0x46)

Input Instance	Word	Byte	Bit 7	Bit 6	Bit 5	Bit 4	Bit 3	Bit 2	Bit 1	Bit 0	
70	0	0	-	-	-	-	-	Faulted	-	Running	
		1	-								
	1	2	Voltage Actual (Low Byte)								
		3	Voltage Actual (High Byte)								

Name	Description
Running	Running
Faulted	Faulted 0: No Fault 1: Fault
Voltage Actual	Actual Converter Voltage Monitors the converter output voltage. Voltage actual data: Output Voltage x 2VS (VS: Voltage scale) Setting range: 0 - FFFF (Hex.) For example, when the output voltage is 1024 and the voltage scale is 2: Voltage actual data = $1024 \times 2^2 = 4096 = 1000$ (Hex.)

◆ EtherNet/IP Extended Speed Control Input - 71 (0x47)

Input Instance	Word	Byte	Bit 7	Bit 6	Bit 5	Bit 4	Bit 3	Bit 2	Bit 1	Bit 0	
71	0	0	-	Net Ref	Net Ctrl	Ready	During Regenerative Operation	Running	Warning	Faulted	
		1	State								
	1	2	Voltage Actual (Low Byte)								
		3	Voltage Actual (High Byte)								

Name	Description
Faulted	Faulted 0: No Fault 1: Fault
Warning	Warning 0: No Warning Occurred 1: Warning Occurred
Running	Running
During Regenerative Operation	Converter in regenerative operation
Ready	Ready 0: Not Ready 1: Ready

Name	Description
Net Ctrl	Run command is from network 0: Run command is not from network 1: Run command is from network
Net Ref	Voltage command is from network 0: Voltage command is not from network 1: Voltage command is from network
State	Contains the value from the Control Supervisor (Class 0x29) Instance 1 Attribute 6.
Voltage Actual	Actual Converter Voltage Monitors the converter output voltage. Voltage actual data: Output Voltage x 2VS (VS: Voltage scale) Setting range: 0 - FFFF (Hex.) For example, when the output voltage is 1024 and the voltage scale is 2: Voltage actual data = 1024 x 2 ² = 4096 = 1000 (Hex.)

12 Web Interface

The option contains a series of web pages that let you use a standard web browser to view status and diagnostic information.

The web page is accessed through a self-contained web server at port 80. Type the IP address of the option into a web browser to access the home page. Example: "http://192.168.1.20" The IP address of the option can be read using monitors *U6-80 to U6-83 [Option IP Address 1 to Option IP Address 4]* on the keypad if it is unknown. Refer to [Table 6.1](#) for more information.

- Home Page
- EtherNet/IP Page
- Network Page

◆ Home Page

The Home page shows the status of the drive and the I/O. It also shows identifying information about the drive and the option.

YASKAWA CIPR-GA80U2008
EtherNet/IP / SI-EN3

Home EtherNet/IP Network

Status Extended Status

Drive Status

Ready

RUN ZERO SPD REV RESET AT SPD READY ALARM FAULT

Drive Monitors

Frequency Reference	0.00 Hz
Output Frequency	0.00 Hz
Motor Speed	0.00 Hz
Output Current	0.0 A
DC Bus Voltage	336 VDC
Torque Reference	0.0 %

Digital Inputs

<input type="checkbox"/>	S1
<input type="checkbox"/>	S2
<input type="checkbox"/>	S3
<input type="checkbox"/>	S4
<input type="checkbox"/>	S5
<input type="checkbox"/>	S6
<input type="checkbox"/>	S7
<input type="checkbox"/>	S8

Digital Outputs

<input type="checkbox"/>	M1-M2
<input checked="" type="checkbox"/>	M3-M4
<input type="checkbox"/>	M5-M6

Analog Inputs

A1	<input type="text"/>	0.0 %
A2	<input type="text"/>	0.0 %
A3	<input type="text"/>	0.0 %

Drive

Model	GA800
Full Model	CIPR-GA80U2008
Version	9010
Serial Number	

Option Card

Model	SI-EN3
Version	VST904104 (R0)
Protocol	EtherNet/IP
Serial Number	20000002

©2020 Yaskawa America, Inc. All Rights Reserved - WEB 424 (R0) Update Time: 1 sec

Figure 12.1 Home Page View

◆ EtherNet/IP Page

The EtherNet/IP page shows basic information about the protocol. Up to two connections can be active at a time. The connections will show which assemblies are used and what type of connection it is.

At the bottom of the page, the EDS file for attached drive can be downloaded. This can be used in the PLC software.

The screenshot shows the Yaskawa EtherNet/IP web interface. At the top, there are navigation tabs for 'Home', 'EtherNet/IP', and 'Network'. The main content area is titled 'No Active Connection' and displays a table of connection parameters, all with values of 0. Below this is a 'Downloads' section with a file named 'EDS File: CIPR-GA80U2008' and a 'Download' button. The footer contains the copyright notice '©2020 Yaskawa America, Inc. All Rights Reserved - WEB 424 (R0)' and the 'Update Time: 1 sec'.

No Active Connection	
Originator IP Address	0.0.0.0
Timeout Multiplier	0
O2T RPI	0
O2T API	0
T2O RPI	0
T2O API	0
Consume Message Count	0
Produce Message Count	0

Downloads

EDS File: CIPR-GA80U2008

©2020 Yaskawa America, Inc. All Rights Reserved - WEB 424 (R0) Update Time: 1 sec

Figure 12.2 EtherNet/IP Page View

Network Monitor	Explanation
Originator IP Address	The IP address of the master PLC on the network
Timeout Multiplier	If a packet is not received in the time specified by the RPI times the Connection Timeout Multiplier, the connection is broken.
O2T RPI	Requested Packet Interval between the originator (PLC) and the target (drive)
O2T API	Actual Packet Interval between the originator (PLC) and the target (drive)
T2O RPI	Requested Packet Interval between the target (drive) and the originator (PLC)
T2O API	Actual Packet Interval between the target (drive) and the originator (PLC)
Consume Message Count	Cumulative number of messages received from the PLC
Produce Message Count	Cumulative number of messages sent to the PLC

Note:

Cumulative counters are reset when the power supply is cycled.

◆ Network Page

The embedded network monitor page shows the status of the option network traffic and open I/O connections.

YASKAWA

CIPR-GA80U2008
EtherNet/IP / SI-EN3

Home	EtherNet/IP	Network
Identity		
IP Address	192.168.1.20	
Subnet Mask	255.255.255.0	
Gateway Address	192.168.1.254	
MAC Address	00:20:85:88:20:20	
Address Mode	Static	
Status		
Link Status	Active	
Speed	100 Mbps	
Duplex	Full	
Auto-Negotiation	Successful	
Misc		
Retry	0	
Collisions	0	
Current Connections	0	
Packet Counters		
Ok	1176	1454
Errors	0	0
Dropped	0	0
Interface Counters		
In Octets		217560
In Ucast Packets		1344
In NUcast Packets		235
Out Octets		241556
Out Ucast Packets		1117
Out NUcast Packets		10
Media Counters		
Alignment Errors		0
FCS Errors		0
Single Collisions		0
Multiple Collisions		0
Late Collisions		0
Deferred Collisions		0
Excessive Collisions		0
Frame Too Large		0
©2020 Yaskawa America, Inc. All Rights Reserved - WEB 424 (R0)		
Update Time: 1 sec		

Figure 12.3 Network Page View

Network Monitor	Explanation
Msg Tx OK	Cumulative number of messages transmitted successfully from the option.
Msg Rx OK	Cumulative number of messages received successfully to the option.
Msg Tx Dropped	Cumulative number of messages dropped due to output network buffer being full and unable to hold the new message.

Network Monitor	Explanation
Msg Rx Dropped	Cumulative number of messages dropped due to input network buffer being full and unable to hold the new message.
Collisions	Cumulative number of collisions (half duplex only) reported by the MAC/PHY (Media Access Control/Physical Connection).
Msg Tx Errors	Cumulative number of transmit underruns and transmit stops reported by the MAC/PHY.
Msg Rx Errors	Cumulative number of receive overruns, receive stops, and receive error frames reported by the MAC/PHY.
Tx Retry	Cumulative number of transmits in which the 1st attempt was delayed due to busy medium reported by the MAC/PHY.
Current Connections	Current number of open connections.
IP Address	IP Address of the option.
Subnet Mask	Subnet Mask of the option.
Gateway Address	The Gateway IP Address that the option will use.
MAC Address	MAC Address of the option.
Address Mode	Either static IP address or DHCP.
Link Status	Active if the cable is plugged in, or inactive if no cable.
Speed	Connection speed, either 10 Mbps or 100 Mbps.
Duplex	Display either Full or Half.
Auto-Negotiation	If auto-negotiation is enabled, this will show the status of the negotiation.
In Octets	Cumulative number of incoming octets.
In Ucast Packets	Cumulative number of unicast packets received.
In NUcast Packets	Cumulative number of non-unicast packets received.
Out Octets	Cumulative number of outgoing octets.
Out Ucast Packets	Cumulative number of unicast packets sent.
Out NUcast Packets	Cumulative number of unicast packets sent.
Alignment Errors	Cumulative number of errors for uneven packets lengths.
FCS Errors	Cumulative number of frame check sequence errors.
Single Collisions	Cumulative number of single collisions.
Multiple Collisions	Cumulative number of multiple collisions.

Network Monitor	Explanation
Late Collisions	Cumulative number of late collisions.
Deferred Collisions	Cumulative number of deferred collisions.
Excessive Collisions	Cumulative number of excessive collisions.
Frame Too Large	Cumulative number of frames that exceed the maximum frame size.

Note:

Cumulative counters are reset when the power supply is cycled.

13 Troubleshooting

◆ Drive-Side Error Codes

Drive-side error codes appear on the drive keypad. *Faults on page 71* lists causes of the errors and possible corrective actions. Refer to the drive Technical Manual for additional error codes that may appear on the drive keypad.

■ Faults

Both *bUS [Option Communication Error]* and *EF0 [Option Card External Fault]* can appear as a fault. When a fault occurs, the keypad ALM LED stays lit. When an alarm occurs, the ALM LED flashes.

If communication stops while the drive is running, use these questions as a guide to help remove the fault:

- Is the communication line properly connected to the option? Is it loose?
- Is the option properly installed?
- Is the PLC program working? Is the controller/PLC CPU stopped?
- Did a momentary power loss interrupt communications?

Code	Name	Causes	Possible Solutions
bUS	Option Communication Error	The drive did not receive a signal from the controller.	<ul style="list-style-type: none"> • Check for wiring errors. • Correct the wiring.
		The communications cable wiring is incorrect.	
		An existing short circuit or communications disconnection	Check disconnected cables and short circuits and repair as needed

Code	Name	Causes	Possible Solutions
		A data error occurred due to electric interference	<ul style="list-style-type: none"> Prevent noise in the control circuit, main circuit, and ground wiring. If you identify a magnetic contactor as a source of noise, install a surge absorber to the contactor coil. Use only recommended cables or other shielded line. Ground the shield on the controller side or the drive input power side. Separate all communication wiring from drive power lines. Install an EMC noise filter to the drive power supply input. Decrease the effects of electrical interference from the controller.
		Option is damaged	If there are no problems with the wiring and the error continues to occur, replace the option.
		Connection Time-out	Check if the CPU of the controller is not stopped.
		Duplicate IP Address found on network	Change to a different IP address. If <i>F7-13 = 0 [Address Mode at Startup = Static]</i> , change parameters <i>F7-01 to F7-04 [IP Address 1 to 4]</i> .
EF0	Option Card External Fault	The option received an external fault from the controller.	<ol style="list-style-type: none"> Find the device that caused the external fault and remove the cause. Clear the external fault input from the controller.
		A programming error occurred on the controller side.	Examine the operation of the controller program.
oFA00	Option Not Compatible with Port	The option connected to connector CN5-A is not compatible.	<p>Connect the option to the correct connector.</p> <ul style="list-style-type: none"> Use connector CN5-A when you connect the option. To use other options, refer to those option manuals.
oFA01	Option Card Fault (CN5-A)	The option connected to option port CN5-A was changed during run.	<ol style="list-style-type: none"> De-energize the drive. Connect the option to the correct option port.
oFA03, oFA04	Option Card Error (CN5-A)	A fault occurred in the option.	<ol style="list-style-type: none"> De-energize the drive. Make sure that the option is correctly connected to the connector. If the problem continues, replace the option.

Code	Name	Causes	Possible Solutions
oFA30 to oFA43	Option Card Connection Error (CN5-A)	A fault occurred in the option.	<ol style="list-style-type: none"> 1. De-energize the drive. 2. Make sure that the option is correctly connected to the connector. 3. If the problem continues, replace the option.
oFb00	Option Not Compatible with Port	The option connected to connector CN5-B is not compatible.	<p>Connect the option to the correct connector.</p> <ul style="list-style-type: none"> • Use connector CN5-A when you connect the option. To use other options, refer to those option manuals.
oFb02	Option Fault	An option of the same type is already installed in option port CN5-A, CN5-B, or CN5-C.	Connect the option to the correct option port.
oFC00	Option Fault (CN5-B)	The option connected to connector CN5-C is not compatible.	<p>Connect the option to the correct connector.</p> <ul style="list-style-type: none"> • Use connector CN5-A when you connect the option. To use other options, refer to those option manuals.
oFC02	Option Fault	An option of the same type is already installed in option port CN5-A, CN5-B, or CN5-C.	Connect the option to the correct option port.

■ Minor Faults and Alarms

Code	Name	Causes	Possible Solutions
CyPo	Cycle Power to Active Parameters	Comm. Option Parameter Not Upgraded	Re-energize the drive to update the communication option parameters.

◆ Explicit Message Communications Errors

When there is a problem with a request message sent from the master in explicit communications, the drive will return one of the error codes shown in [Table 13.1](#).

Table 13.1 Communications Errors and Solutions

Error Code (Hex.)	Description	Cause	Possible Solutions
08	Service not supported	The service code is incorrect.	Correct the service code.
09	Invalid attribute value	The attribute is incorrect.	Correct the attribute.

Error Code (Hex.)	Description	Cause	Possible Solutions
0C	Object state conflict	Attempted to change a drive parameter that cannot be changed while the drive is running.	Stop the drive.
0E	Attribute not settable	Attempted to change a read-only attribute.	Correct the service code or attribute setting.
13	Not enough data	The data size is incorrect.	Correct the data size.
14	Attribute not supported	Attempted to execute a service not defined for the attribute.	Correct the service code or attribute setting.
15	Too much data	The data size is incorrect.	Correct the data size.
16	Object does not exist	An unsupported object was specified.	Correct the class or instance setting.
1F	Vendor-specific error	<ul style="list-style-type: none"> Attempted to change a drive parameter that cannot be changed while the drive is running. Attempted to change a drive parameter to a value outside the setting range. 	<ul style="list-style-type: none"> Stop the drive. Specify a value within the setting range.
20	Invalid parameter	Attempted to change to a data value outside the setting range.	Specify a data value within the setting range.

◆ Option Error Codes

■ Option Fault Monitors *U6-98* and *U6-99*

The option can declare error/warning conditions via drive monitor parameters on the drive keypad as shown in [Table 13.2](#).

Table 13.2 Option Fault Monitor Descriptions

Status	Fault Declared	Status Value (U6-98/U6-99)	Description
No faults	-	0	No faults
Fatal error occurred	<i>EF0</i>	3	Network sent a message to force this node to the fault state.
Network Link Down	<i>bUS</i>	1100	No network link to option.
Communications time-out (non-fatal)	<i>bUS</i>	1101	The node timer (Requested Packet Interval) timed out.

Status	Fault Declared	Status Value (U6-98/ U6-99)	Description
Duplicate IP Address	<i>bUS</i>	1102	This node and at least one other node have the same IP Address.
Default MAC Address	-	1103	Factory default MAC Address programmed into the option. Note: Return the option to Yaskawa or your nearest sales representative and request the setting change.

Two drive monitor parameters, *U6-98 [First Fault]* and *U6-99 [Current Fault]* assist the user in network troubleshooting.

- *U6-98* displays the first declared fault since the last power cycle. *U6-98* is only cleared upon drive power-up.
- *U6-99* displays the present option status. *U6-99* is cleared upon a network-issued fault reset and upon power-up.

If another fault occurs while the original fault is still active, parameter *U6-98* retains the original fault value and *U6-99* stores the new fault status value.

◆ Option Compatibility

You can connect a maximum of 3 options at the same time depending on the type of option.

Note:

- You can only connect one option to the GA500 and HV600 drives. Connect the option to the CN5 connector.
- You can connect two options to an FP605 drive. Connect the communication option to the CN5-A connector.
- Compatible communication options are different for different models. Refer to the drive manuals for more information.

Table 13.3 Option Compatibility

Option	Connector	Number of Options Possible
PG-B3 *1, PG-X3 *1	CN5-B, C	2 *2
PG-RT3 *1 *3 *4, PG-F3 *1 *3 *4	CN5-C	1
DO-A3 *5, AO-A3 *5	CN5-A, B, and C	1
SI-C3, SI-N3, SI-P3, SI-S3, SI-T3, SI-ET3, SI-ES3, SI-B3, SI-M3, SI-W3 *4, SI-EM3 *4, SI-EM3D *4, SI-EN3 *4, SI-EN3D *4, SI-EP3, JOHB-SMP3, AI-A3 *5 *6, DI-A3 *5 *6	CN5-A	1

14 Option Installation

- *1 Not available for GA500, HV600, or FP605 drives.
- *2 To connect two PG options, use the CN5-C and CN5-B connectors. To connect only one PG option, use the CN5-C connector.
- *3 If you use the motor switching function, you cannot use this option.
- *4 Not available for 1000-Series drive models with capacities between 450 and 630 kW (650 to 1000 HP).
- *5 Not available for GA500 or HV600 drives.
- *6 To use AI-A3 and DI-A3 input statuses as monitors, connect the options to CN5-A, CN5-B, or CN5-C.

14 Option Installation

Verify the following installation conditions to make sure that other devices and machinery used with this option and drive also comply with EMC guidelines:

1. Use dedicated shield cable for the option and external device (encoder, I/O device, master), or run the wiring through a metal conduit.
2. Keep wiring as short as possible and ground the largest possible surface area of the shield to the metal panel according to [Figure 14.1](#) and [Figure 14.2](#).

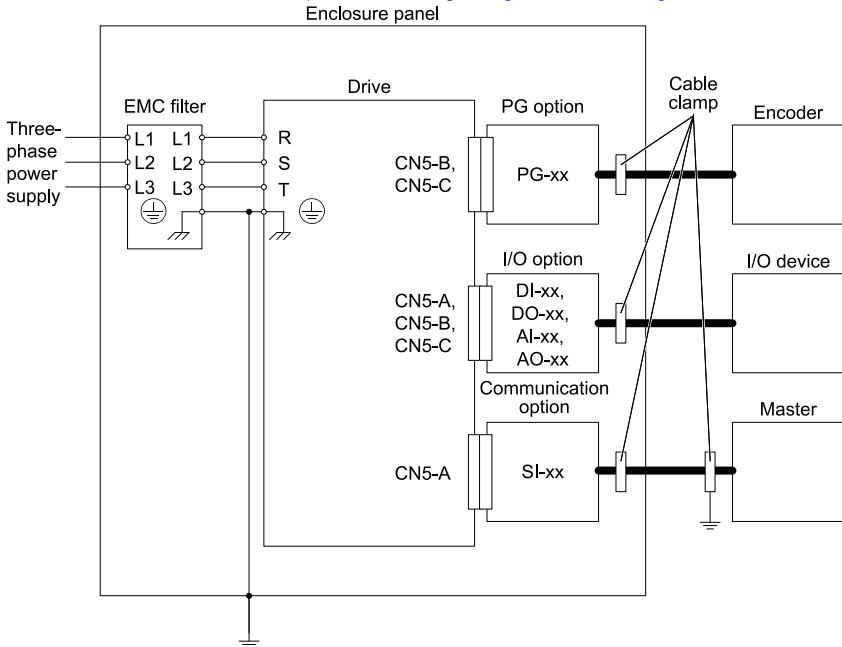

Figure 14.1 Option Installation for CE Compliance: 1000-Series, GA700, GA800, CR700, CH700

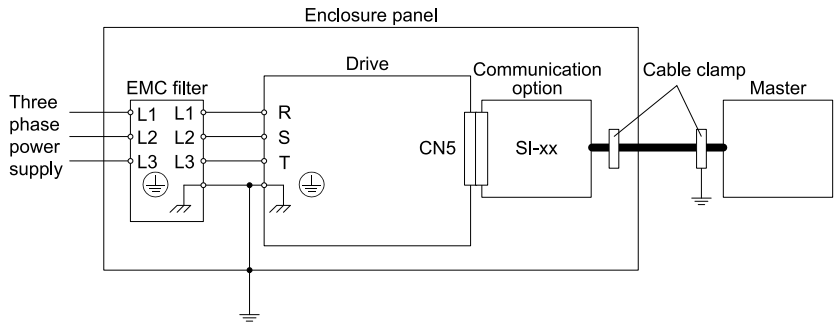

Figure 14.2 Option Installation for CE Compliance: GA500, HV600

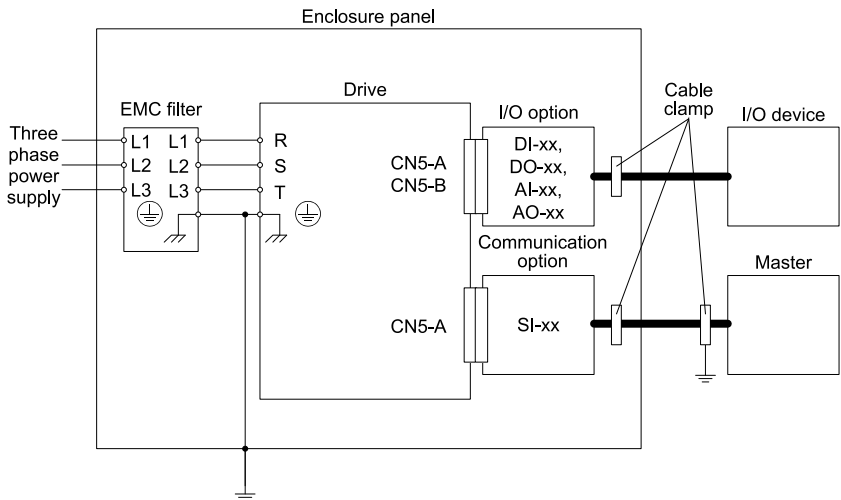
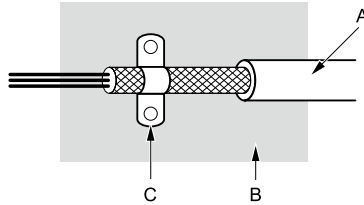

Figure 14.3 Option Installation for CE Compliance: FP605

3. Ground the largest possible surface area of the shield to the metal panel. Yaskawa recommends using cable clamps.



A - Braided shield cable
 B - Metal panel

C - Cable clamp (conductive)

Figure 14.4 Ground Area

15 Specifications

◆ Specifications

Table 15.1 Option Specifications

Items	Specifications
Model	SI-EN3
Supported Messages	<ul style="list-style-type: none"> • Explicit: Explicit Class 3, Unconnected • I/O: Class 1, Listen Only, Input Only
I/O Assembly Instance	<ul style="list-style-type: none"> • Input: 12 types (4 - 44 Bytes) • Output: 12 types (4 - 44 Bytes)
EtherNet/IP Specification	Conformance Level CT 12: Passed
EtherNet/IP Profile	AC Drive
Recommended Connector Type	Shielded Cat5e cable
Physical Layer Type	Isolated Physical Layer Ethernet
IP Address Setting	Programmable from drive keypad or network
Communication Speed	Programmable from drive keypad or network: 0/100 Mbps, auto-negotiate
Number of Connections	<ul style="list-style-type: none"> • Explicit: 6 • I/O: 2
Duplex Mode	Half-forced, Auto-negotiate, Full-forced
Address Startup Mode	Static, BOOTP, DHCP
Ambient Temperature	-10°C - +50°C (14°F - 122°F)

Items	Specifications
Humidity	Up to 95% RH (no condensation)
Storage Temperature	-20°C - +60°C (-4°F - 140°F) allowed for short-term transport of the product
Area of Use	Indoors and free from: <ul style="list-style-type: none"> • Oil mist, corrosive gas, flammable gas, and dust • Radioactive materials or flammable materials, including wood • Harmful gas or fluids • Salt • Direct sunlight • Falling foreign objects
Altitude	Up to 1000 m (3280 ft)

16 Disposal

◆ Disposal Instructions

Correctly dispose of the product and packing material as specified by applicable regional, local, and municipal laws and regulations.

◆ WEEE Directive



The wheeled bin symbol on this product, its manual, or its packaging identifies that you must recycle it at the end of its product life.

You must discard the product at an applicable collection point for electrical and electronic equipment (EEE). Do not discard the product with usual waste.

Revision History

Date of Publication	Revision Number	Section	Revised Content
January 2026	3	Back cover	Revision: Address
September 2025	2	Back cover	Revision: Address
November 2021	1	All	Addition: Information on FP605 Revision: Reviewed and corrected entire documentation
August 2020	-	-	First Edition This manual is created based on TOBP C730600 92D<3>-0.

YASKAWA AC Drive Option EtherNet/IP Installation Manual

DRIVE CENTER (INVERTER PLANT)

2-13-1, Nishimiyachi, Yukuhashi, Fukuoka,
824-8511, Japan
Phone: +81-930-25-2548 Fax: +81-930-25-3431
www.yaskawa.co.jp

YASKAWA ELECTRIC CORPORATION

New Pier Takeshiba South Tower, 1-16-1, Kaigan,
Minatoku, Tokyo, 105-6891, Japan
Phone: +81-3-5402-4502 Fax: +81-3-5402-4580
www.yaskawa.co.jp

YASKAWA AMERICA, INC.

2121, Norman Drive South, Waukegan, IL 60085, U.S.A.
Phone: +1-800-YASKAWA (927-5292) or +1-847-887-7000
Fax: +1-847-887-7310
www.yaskawa.com

YASKAWA ELÉTRICO DO BRASIL LTDA.

777, Avenida Piraporinha, Diadema, São Paulo,
09950-000, Brasil
Phone: +55-11-3585-1100 Fax: +55-11-3585-1187
www.yaskawa.com.br

YASKAWA EUROPE GmbH

Philipp-Reis-Str. 6, 65795 Hattersheim am Main, Germany
Phone: +49-6196-569-300
www.yaskawa.eu.com
E-mail: support@yaskawa.eu

YASKAWA ELECTRIC KOREA CORPORATION

6F, 112, LS-ro, Dongan-gu, Anyang-si, Gyeonggi-do, Korea
Phone: +82-31-8015-4224 Fax: +82-31-8015-5034
www.yaskawa.co.kr

YASKAWA ASIA PACIFIC PTE. LTD.

30A, Kallang Place, #06-01, 339213, Singapore
Phone: +65-6282-3003 Fax: +65-6289-3003
www.yaskawa.com.sg

YASKAWA ELECTRIC (THAILAND) CO., LTD.

59, 1F-5F, Flourish Building, Soi Ratchadapisek 18,
Ratchadapisek Road, Huaykwang, Bangkok, 10310,
Thailand
Phone: +66-2-017-0099 Fax: +66-2-017-0799
www.yaskawa.co.th

YASKAWA ELECTRIC (CHINA) CO., LTD.

22F, Link Square 1, No.222, Hubin Road, Shanghai,
200021, China
Phone: +86-21-5385-2200 Fax: +86-21-5385-3299
www.yaskawa.com.cn

YASKAWA ELECTRIC (CHINA) CO., LTD.

BEIJING OFFICE
Room 1011, Tower W3 Oriental Plaza, No. 1,
East Chang An Avenue,
Dong Cheng District, Beijing, 100738, China
Phone: +86-10-8518-4086 Fax: +86-10-8518-4082

YASKAWA ELECTRIC TAIWAN CORPORATION

12F, No. 207, Section 3, Beishin Road, Shindian District,
New Taipei City 23143, Taiwan
Phone: +886-2-8913-1333
Fax: +886-2-8913-1513 or +886-2-8913-1519
www.yaskawa.com.tw

YASKAWA INDIA PRIVATE LIMITED

#17/A, Electronics City, Hosur Road, Bengaluru,
560 100 (Karnataka), India
Phone: +91-80-4244-1900 Fax: +91-80-4244-1901
www.yaskawaindia.in

YASKAWA

YASKAWA ELECTRIC CORPORATION

In the event that the end user of this product is to be the military and said product is to be employed in any weapons systems or the manufacture thereof, the export will fall under the relevant regulations as stipulated in the Foreign Exchange and Foreign Trade Act. Therefore, be sure to follow all procedures and submit all relevant documentation according to any and all rules, regulations and laws that may apply.

Specifications are subject to change without notice for ongoing product modifications and improvements.

© 2020 YASKAWA ELECTRIC CORPORATION



TOEPC73060092

MANUAL NO. TOEP C730600 92B <3>-J0
Published in Japan January 2026
25-9-27
Original Instructions